

**LOCKHEED HYDRAULIC
BRAKE COMPANY LTD.**

**TWO LEADING SHOE
HYDRAULIC
BRAKES**

**SERVICE
MANUAL**



One of the Automotive Products Group

AUTOMOTIVE PRODUCTS COMPANY LTD.

**SERVICE & SPARE PARTS DIVISION
P.O. BOX 14, SOUTHAM ROAD, BANBURY**

Telephone: Banbury 4421

Telegrams: "Autoducts" Banbury, Telex

Telex No. 83106

London Office

AUTOMOTIVE HOUSE, LANGHAM STREET, LONDON, WIN 6AT

Telephone: 01-580 2527

Telex No. 23446



TWO LEADING SHOE HYDRAULIC BRAKING AND CLUTCH OPERATING SYSTEMS

INDEX

CARS AND LIGHT COMMERCIAL VEHICLES

	<i>Page</i>
SECTION 1	
DESCRIPTION AND OPERATION	3
SECTION 2	
ROUTINE ATTENTION	7
SECTION 3	
ADJUSTMENTS	9
SECTION 4	
OVERHAUL INSTRUCTIONS	13
SECTION 5	
"BLEEDING" AND FLUSHING	23
SECTION 6	
FAULT FINDING	25
SECTION 7	
THE CLUTCH SYSTEM	27

HEAVY COMMERCIAL VEHICLES

SECTION 8	31
------------------------	----

DEFINITION
The definition of a system is a statement that describes the system in terms of its purpose, its boundaries, and its components. It is a statement that is true for all possible states of the system. The definition of a system is a statement that describes the system in terms of its purpose, its boundaries, and its components. It is a statement that is true for all possible states of the system.

PRINCIPLES OF OPERATION
The principles of operation of a system are the rules that govern the system's behavior. They are the rules that determine how the system's components interact with each other and with the environment. The principles of operation of a system are the rules that govern the system's behavior. They are the rules that determine how the system's components interact with each other and with the environment.

SECTION I

DESCRIPTION AND OPERATION

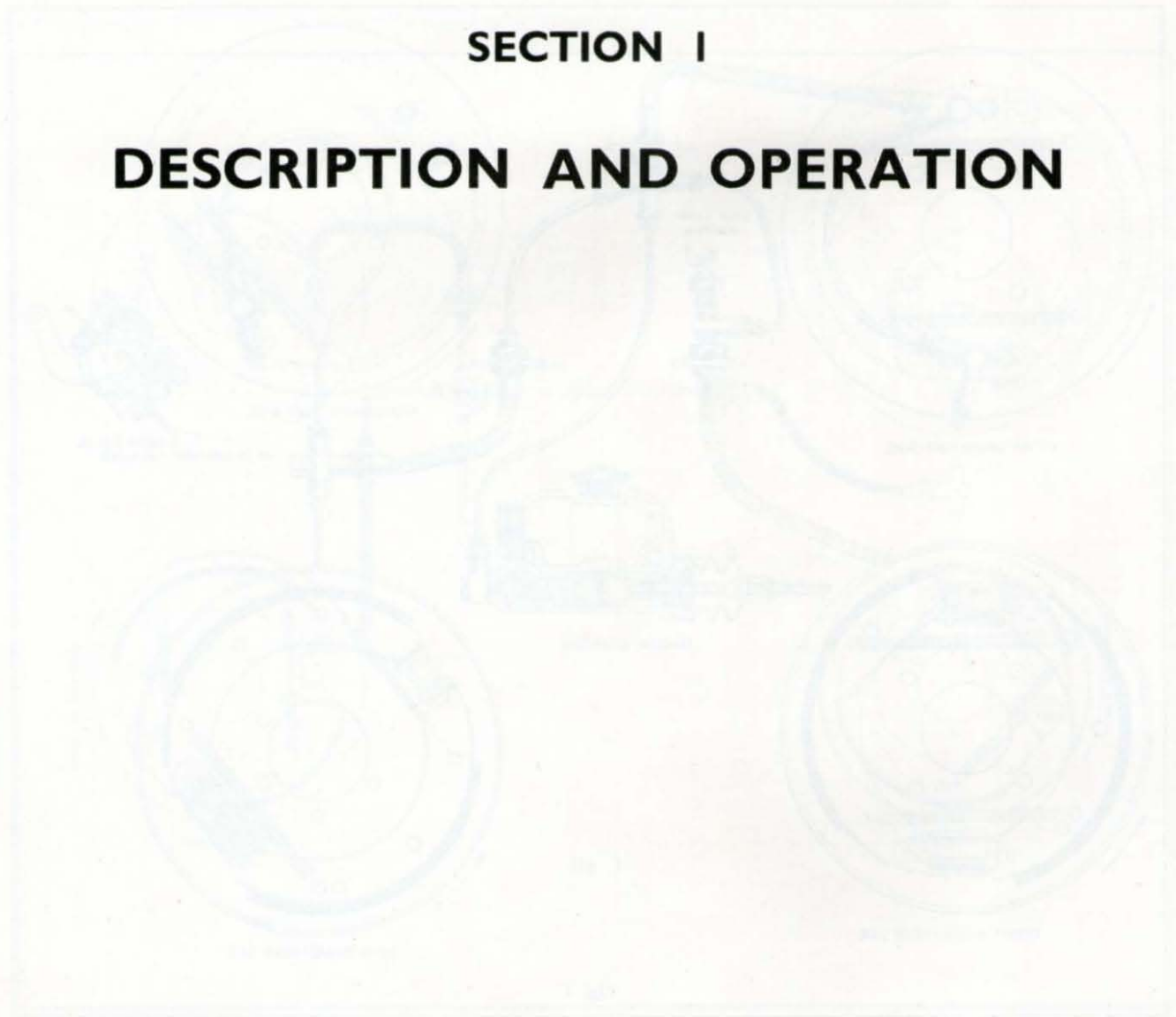

DESCRIPTION

The Lockheed two-leading shoe hydraulic brake equipment used on cars and light commercial vehicles is shown diagrammatically on Fig. 1 and Fig. 2 and consists of a master cylinder of the integral barrel type, containing a reserve supply of fluid, in which hydraulic pressure is generated; single-ended internal wheel cylinders which operate the two leading shoe front brakes; single-ended internal cylinders, incorporating handbrake operating levers, which operate the leading and trailing shoe rear brakes, and the "line" consisting of tubing, flexible hoses and unions interposed between the master cylinder and the wheel cylinders. In addition to the braking system, certain vehicles also incorporate a hydraulic clutch operating system consisting of a master cylinder connected to a slave cylinder which operates the release bearing mechanism of the clutch.

PRINCIPLE OF OPERATION

In the Lockheed hydraulic brake, the pressure exerted on the brake pedal is conveyed to the brake shoes by a column of special Lockheed fluid; the master cylinder has a single piston, likewise the wheel cylinders, and all pistons are provided with rubber cups or seals to maintain pressure and prevent loss of fluid.

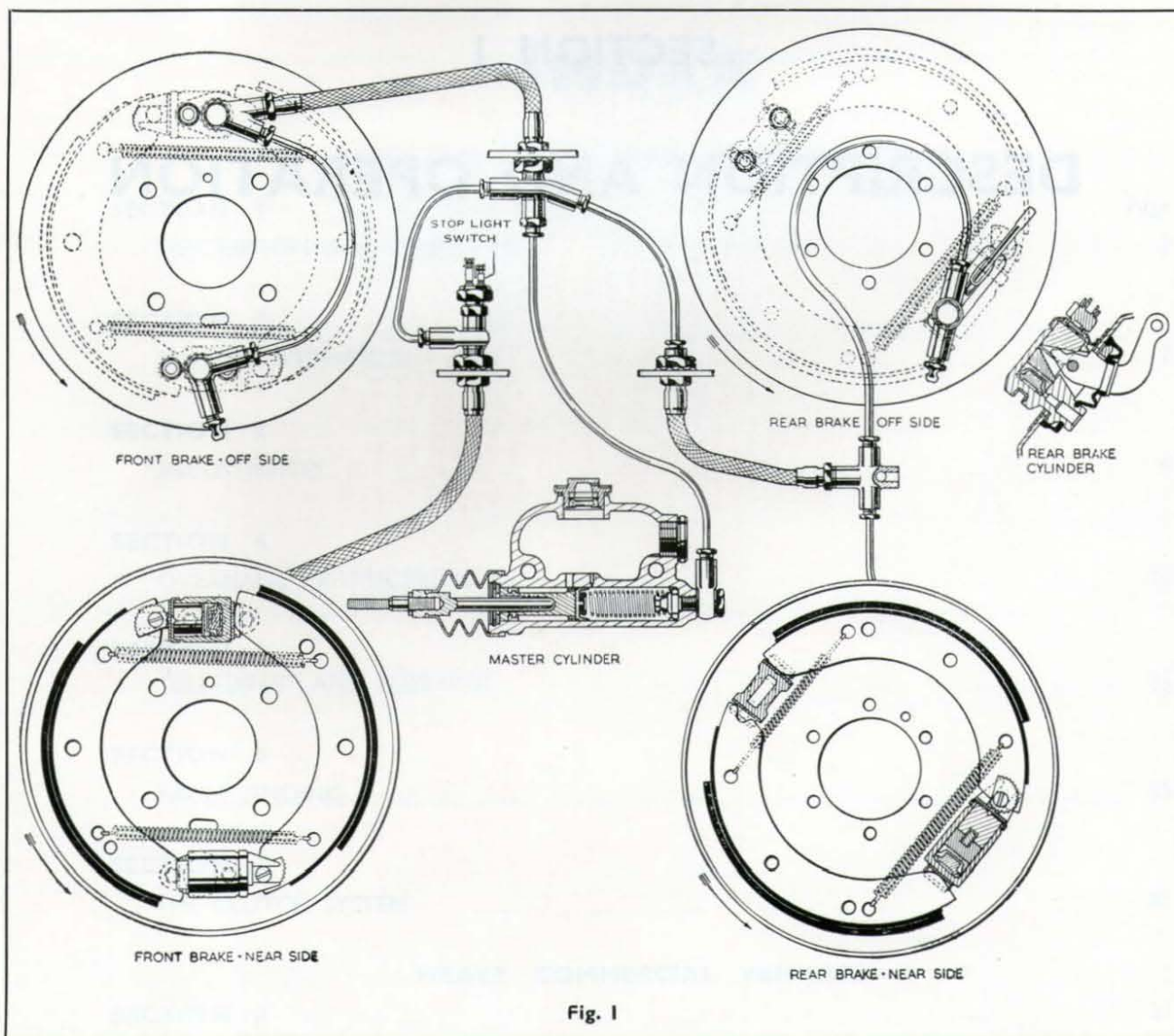

Fig. 1

PRINCIPLE OF OPERATION (continued)

When the brake pedal is depressed the master cylinder piston applies a force to the fluid which, being incompressible, is displaced through the pipes causing the single piston in each front wheel cylinder to apply a pressure to the leading tip of its respective brake shoe, while the trailing tip of the shoe finds a floating anchor by utilising the closed end of the actuating cylinder of the other shoe as its abutment. At the same time the rear wheel cylinder, which is free to slide in an elongated slot in the rear backplate between the tips of the leading and trailing shoes, operates on the tip of the leading shoe and this shoe abuts against a fixed anchor block at the bottom of the backplate, the web of the shoe being free to slide in a slot in the block. The trailing shoe is located in a similar manner between the anchor block and the closed end of the wheel cylinder, and is free to slide and therefore self-centring. The trailing shoe is operated by movement of the cylinder assembly as a result of the reaction of the leading shoe against the brake drum. Further effort on the pedal increases the force applied to the brake shoes.

The pressure generated in the master cylinder is transmitted with equal and undiminished force to the piston of each wheel cylinder; therefore the pressures applied to the brake shoes are identical. When the pressure on the brake pedal is released the brake shoe pull-off springs force each wheel cylinder piston back into its respective cylinder and the fluid passes back to the master cylinder ready for the next brake application.

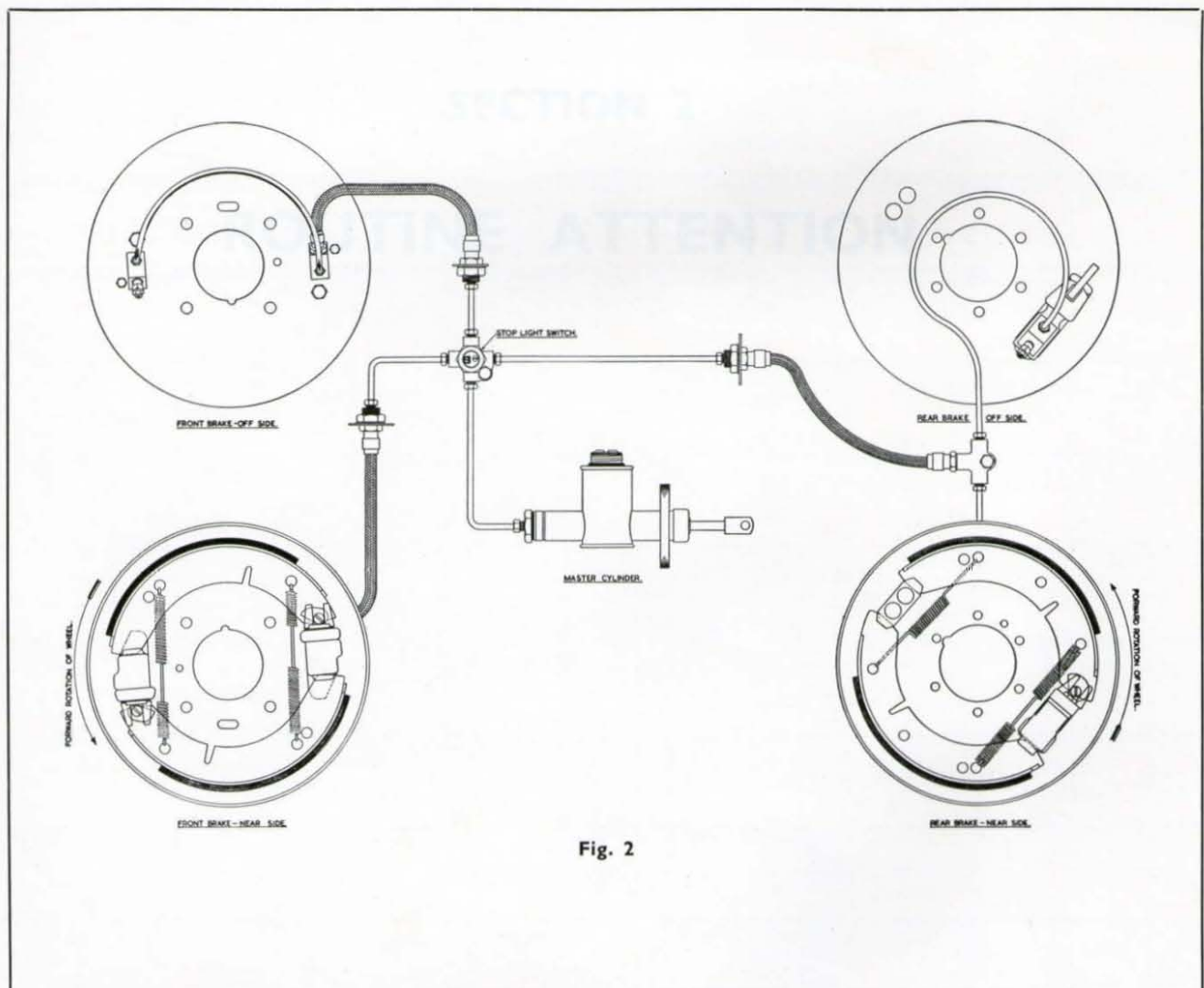
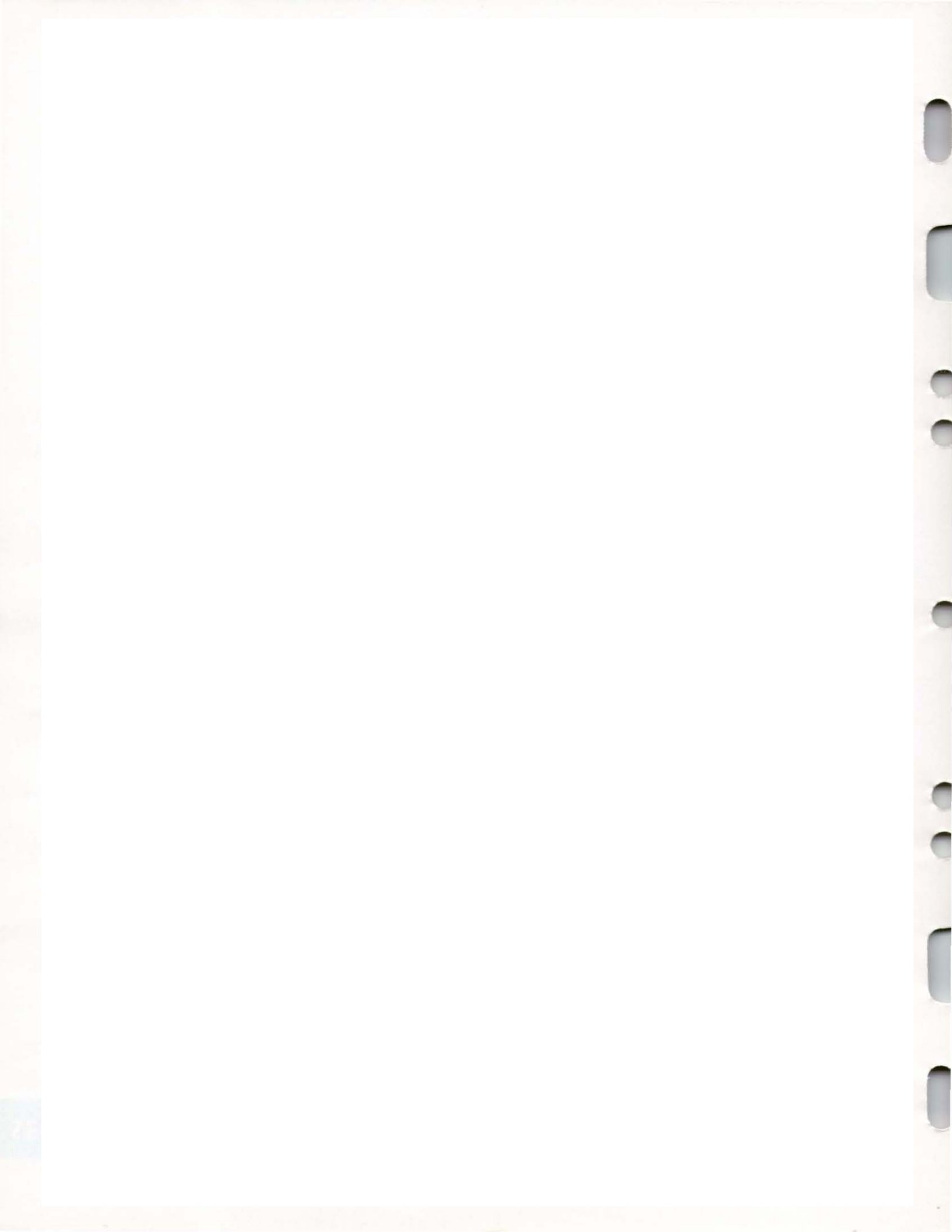

Fig. 2



ROUTINE ATTENTION

SECTION 2

SECTION 2

ROUTINE ATTENTION

- (1) The fluid level in the master cylinder(s) or, if applicable, in the separate supply tank, must be checked every 1,000 miles or once a month (whichever occurs first) and replenished if necessary. Prior to unscrewing the filler cap, clean the area around it to prevent dirt entering when it is removed. The correct fluid level is to within $\frac{1}{4}$ in. below the bottom of the filler cap orifice. Great care should be taken not to spill any brake fluid on the bodywork of the car as this fluid is injurious to paint. Re-fit the filler cap, together with its seal, and securely tighten. **USE ONLY GENUINE LOCKHEED SUPER 105 BRAKE FLUID TO SPEC. S.A.E. J1703 WHEN TOPPING UP.**

The addition of fluid should be required only at extremely long intervals, and a considerable fall in the fluid level would indicate an external leak at some point in the system which should be traced and rectified immediately. To check for leaks, apply firm pressure to the brake pedal whilst an assistant examines the units, pipes, hoses and fittings; if a hydraulic clutch-operating system is fitted to the vehicle, check this also for leaks.

- (2) Ensure that the air vents in the filler caps are not choked, since blockage would cause the brakes to drag and the clutch to slip (if the clutch is hydraulically operated).
- (3) The brake shoes should be re-adjusted when the free travel of the brake pedal is excessive (this is the movement of the pedal before the brakes become effective).
- (4) Every 5,000 miles examine brake linings and renew if worn to less than a third of their original thickness. Check brake drums for excessive wear and ensure that linings are not contaminated by lubricating oil or grease. Whilst doing this, also check for wheel cylinder and master cylinder leakage.
- (5) Brake hoses must be inspected every 10,000 miles for any signs of leakage, chafing or general deterioration. If there is any doubt renew the hose. It is recommended in any case that hoses are replaced at least every 3 years or 40,000 miles. When checking hoses, also inspect metal pipes for corrosion or looseness.
- (6) At intervals not exceeding 3 years or 40,000 miles, or at each third change of a brake lining, whichever occurs first, fit exchange cylinders or renew all rubber cups and seals throughout the system.
- (7) At intervals not exceeding eighteen months or twenty four thousand miles, whichever ever occurs first, the fluid should be completely drained from the system and refilled with new Lockheed Super 105 Brake Fluid.
- (8) This operation must be carried out under strictly controlled conditions, *i.e.* great care must be taken to see that any containers or dispensers used for filling the braking system are completely free of water. Brake fluid, particularly disc brake fluid absorbs water from the atmosphere and it is, therefore, essential that fluid is only exposed to atmosphere during the time it takes to fill the system. It is also most important that extreme care is taken to see that dirt or dust of any kind is prevented from entering the system during the filling operation.

USE OF THE GENUINE LOCKHEED FLUID

The special fluid used in Lockheed brakes is one of the most important factors in the correct operation of the hydraulic system, for no equipment will give satisfaction with incorrect fluid. When topping up or overhauling the system use only the genuine Lockheed Super 105 Brake Fluid to Spec. S.A.E. J1703 for it lengthens the life of all internal parts, acts as an efficient lubricant and operates satisfactorily under all extremes of temperature throughout the world. **The use of any other fluid nullifies all guarantees.**

SECTION 3

ADJUSTMENTS

BRAKE PEDAL ADJUSTMENT

In order to ensure the complete return of the piston in the brake master cylinder, it is necessary to provide a minimum clearance between the piston and the push rod which operates it, so ensuring that the piston is fully back against its stop when the pedal is released. This is important, since if the piston is prevented from returning fully the lip of the main cup will cover the by-pass port and prevent the escape to tank of the excess fluid drawn into the cylinder during the return stroke of the piston; the brakes would, therefore, drag or remain "on".

With some master cylinders, the clearance is automatically obtained, but with others it is achieved by manual adjustment of the push-rod; the latter can easily be distinguished since the push-rod is threaded and fitted with a locknut, it is with this type that the following is concerned.

The correct pedal adjustment is set when the vehicle is assembled and should never need alteration. A minimum clearance of $\frac{1}{32}$ " is necessary between the push-rod and the piston, which gives a safety margin of $\frac{3}{8}$ "- $\frac{1}{2}$ " free pedal movement at the pedal pad (refer to Fig. 3). This free movement can be felt if the pedal is depressed gently by hand. Should it not be apparent, first check to make sure that the pedal is not being fouled by a displaced mat preventing the

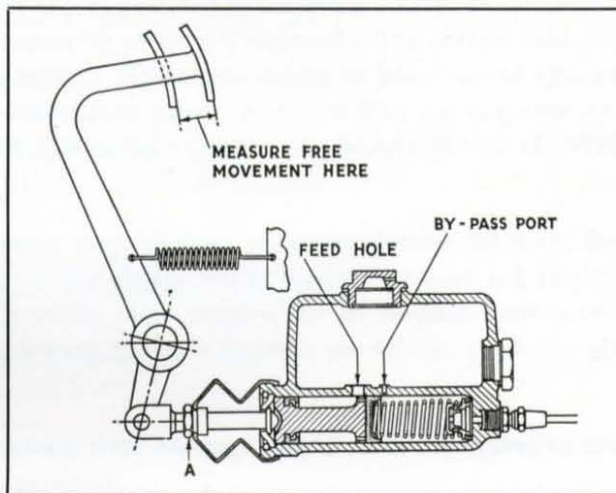

Fig. 3.

complete return of the pedal to the "off" position. In the event of the adjustment having been disturbed, slacken the locknut "A" (Refer to Fig. 3) and reset the length of the push-rod extension until the pedal can be depressed the correct amount before the piston begins to move. Re-tighten the locknut.

BRAKE SHOE ADJUSTMENT

Front Wheels ("Micram" Adjuster).

(Adjusting through brake drum, Fig. 4.)

Remove the wheel dust cap and jack up one wheel until it is free to revolve. Turn the wheel so that the holes in the wheel hub and brake drum are opposite the slotted head of one "Micram" adjuster. Using a



Fig. 4. Adjusting front brake shoes.

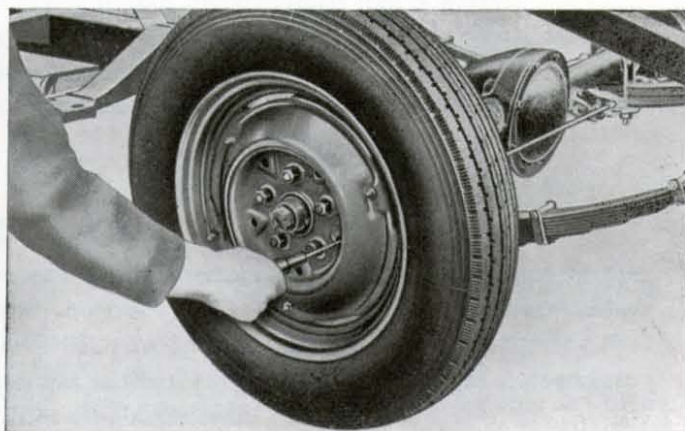

Fig. 5. Adjusting rear brake shoes.

ADJUSTMENTS (continued)

screwdriver (Fig. 4), turn the adjuster in a clockwise direction until the brake shoe is in contact with the brake drum, then turn the adjuster back one notch; this will provide the correct clearance between the shoe and the drum. For closer adjustment spin the drum and apply the brakes hard; this will correctly position the shoe, after which a further adjustment check should be carried out. Repeat these operations on the second adjuster. Adjust the Micrams on the remaining front wheel in the same manner.

Rear Wheels ("Micram" Adjuster).

(Adjusting through brake drum, Fig. 5)

Place chocks under one of the front wheels and release the hand brake. Proceed as for front brake adjustment but noting that there is only one wheel adjuster at each rear wheel (Fig. 5) and that it will be necessary to back off the adjustment the least possible amount to provide adequate clearance for the two shoes.

Front Wheels ("Micram" Adjuster).

(Adjusting from rear of assembly, Fig. 7 & 8)

Jack up one wheel until it is free to revolve. Swing the dust cover away to expose the hole in the backplate and insert a suitable spanner to locate on the Micram square. Turn the adjuster in an anti-clockwise direction until the shoe bears hard against the drum, then back off the adjustment one notch; this will provide suitable clearance between the shoe and the drum. To ensure correct adjustment spin the wheel and apply the brakes hard; this will centralise the shoe, after which a further adjustment check should be carried out. Repeat these operations on the second adjuster. Adjust the Micrams on the other front wheel in the same manner.

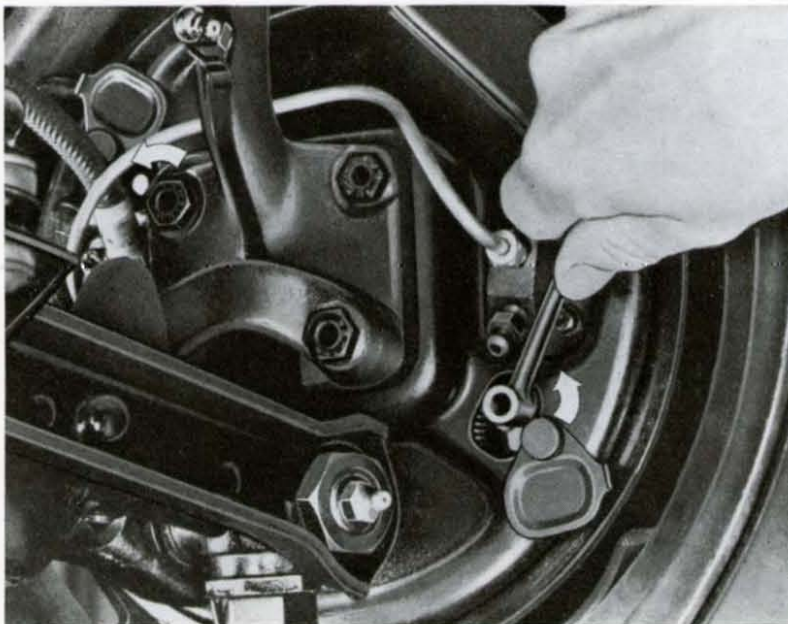

Fig. 7. Showing the adjustment through the backplate.

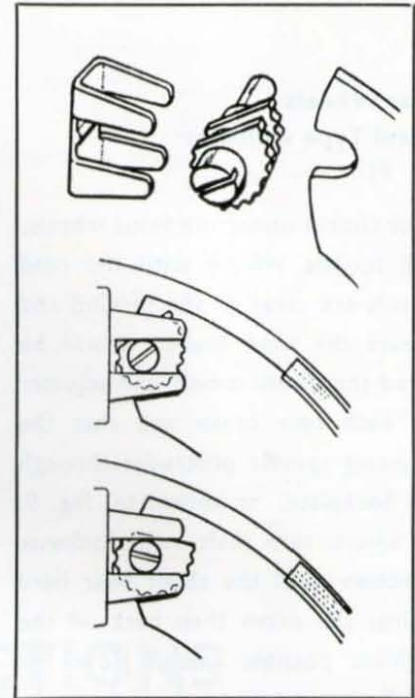

Fig. 6. The component parts of the "Micram" Adjuster.

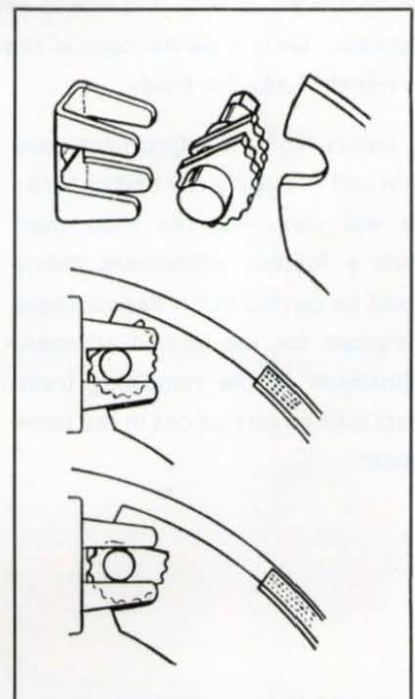

Fig. 8. The component parts of the "Micram" Adjuster, squared rod type

ADJUSTMENTS (continued)

Rear Wheels (Heel Type Adjuster

Fig. 9)

Place chocks under the front wheels; jack up the vehicle until the road wheels are clear of the ground and release the hand brake. It will be noted that there is only one adjuster for each rear brake and that the adjusting spindle protrudes through the backplate, as shown in Fig. 9. To adjust, turn shaft in a clockwise direction until the shoes bear hard against the drum then back off the slightest possible amount (one flat usually being sufficient) until the drum rotates freely. To ensure correct adjustment spin the wheel and apply the brakes hard, after which a further check should be carried out.

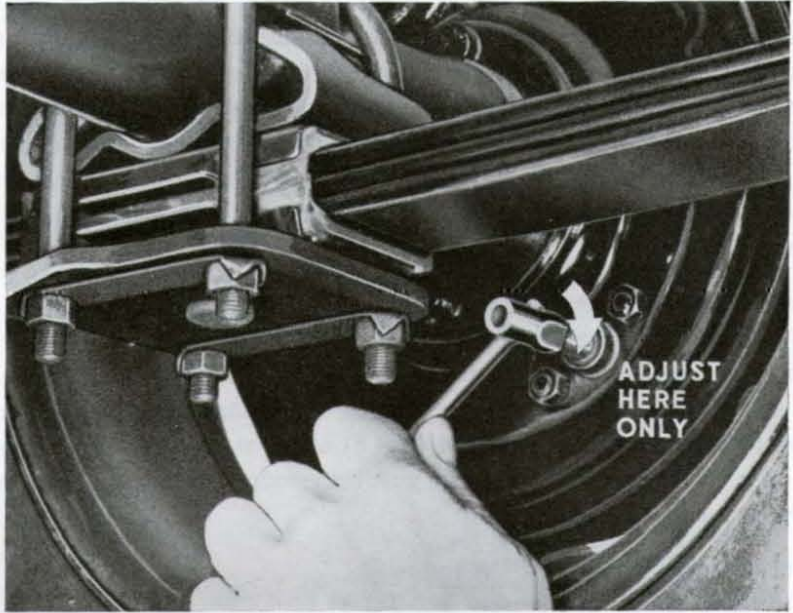

Fig. 9

Front Wheels (Two Point Cam Adjustment, Fig. 10)

Jack up one wheel until it is free to revolve. Turn one adjuster at a time in a clockwise direction until the wheel is locked. Only a partial turn is required. Now back off the adjuster the slightest possible amount to allow the wheel to revolve freely.

To ensure correct adjustment spin the wheel and apply the brakes hard; this will centralise the shoe after which a further adjustment check should be carried out. Repeat these operations for the second adjuster. Adjustment of the remaining front wheel is to be carried out in the same manner.

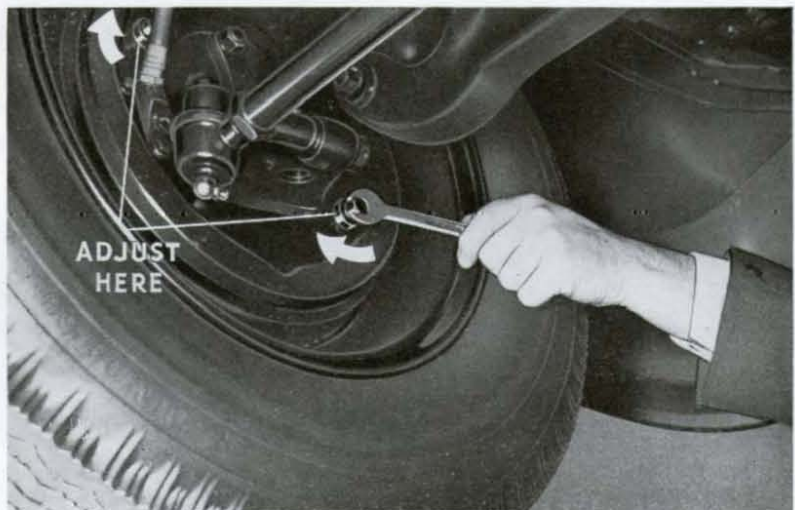

Fig. 10

OVERHAUL INSTRUCTIONS

SECTION 4

OVERHAUL INSTRUCTIONS

	<i>Page</i>
ROUTINE INSTRUCTIONS	14
MASTER CYLINDER (braking system)	14
FRONT BRAKE ASSEMBLY	17
RE-LINING THE BRAKE SHOES	17
REAR BRAKE ASSEMBLY	18
FRONT WHEEL CYLINDER	19
REAR WHEEL CYLINDER	20
REMOVING AND RE-FITTING A FLEXIBLE HOSE	22

ROUTINE INSTRUCTIONS

Should it be found necessary to dismantle the braking or clutch systems, *i.e.* master cylinder, wheel cylinders, or slave cylinder, the operation must be carried out under conditions of scrupulous cleanliness. Clean off the mud and grease before removing the unit. Dismantle on a bench covered with a sheet of clean paper. Do not handle the internal parts—particularly rubbers—with dirty hands. Do not swill a unit, after removal from the vehicle, in paraffin, petrol or trichlorethylene as this will ruin rubber parts and, on dismantling, will give a misleading impression of their original condition. Place all metal parts in a tray of clean brake fluid to soak, afterwards dry off with a clean fluffless cloth and lay out in order on a clean sheet of paper. Rubber parts should be carefully examined and, if there is any doubt of their condition, a comparison should be made with new parts. Any signs of swollen cups or perished rubber indicate that they should be renewed immediately. To ensure unfailing reliability, it is usually advisable to replace all rubber parts with new ones these being readily available in the form of Repair Kits, containing all the rubber components required for a particular unit. The main castings may be swilled in industrial methylated spirit or Lockheed Super 105 Brake Fluid to Spec. S.A.E. J1703 but if spirit is used all traces of the cleaner **must be dried out before assembly**. In the case of the master cylinder, make sure that the by-pass port is clear by probing with a piece of fine wire. The brakes will drag if the by-pass port is clogged as pressure will build up in the system, thereby forcing the shoes into contact with the drums. The port is deliberately drilled first with a $\frac{1}{8}$ " drill halfway and then completed with a .028" drill which just breaks through into the bore. A peening operation at the point of entry into the bore obviates the risk of the main cup tearing on a ragged edge.

All internal parts should be dipped in Lockheed Super 105 Brake Fluid to Spec. S.A.E. J1703 and assembled wet; when assembling rubber parts use the fingers only.

Stores departments should exercise special care in handling brake parts to ensure that no damage is caused which would affect their correct functioning when assembled. Rubbers should be stored in a cold, dark place well removed from any fumes.

MASTER CYLINDER—BRAKING SYSTEM

INTRODUCTION

The type of master cylinder used varies according to the vehicle on which it is fitted; there are three main types, two of which incorporate tanks to hold the reserve of brake fluid whilst the third (shown on Fig. 13) is fed from a separate tank. With the type illustrated in Fig. 11 the tank surrounds the master cylinder barrel and access may be gained by the removal of the filler cap. The cylinder shown on Fig. 12 has the fluid reserve tank cast integrally with the barrel. A further type used, when the clutch also is hydraulically actuated, is the twin-bore master cylinder (shown on Fig. 29). This cylinder houses identical parts in each bore except that the check valve is omitted from the bore which serves the clutch slave cylinder. All types are mounted horizontally and have similar internal parts and function in a similar manner.

DESCRIPTION (Refer to Fig. 14)

A piston (8) is contained within the barrel, and has a rubber main cup (10) spring-loaded against its inner end; between the cup and the piston a thin washer (9) is interposed to prevent the cup from being drawn



Fig. 11



Fig. 12

OVERHAUL INSTRUCTIONS (continued)

into the small feed holes drilled around the piston-head. The outer end of the piston carries a rubber secondary cup (7) and is formed with a depression to receive the spherical end of a push-rod (6) which carries a piston and is retained by a circlip (5) (with the master cylinders illustrated on Figs. 12 and 13 the piston stop takes the form of a separate plain washer). A rubber boot (4), through which the



Fig. 13

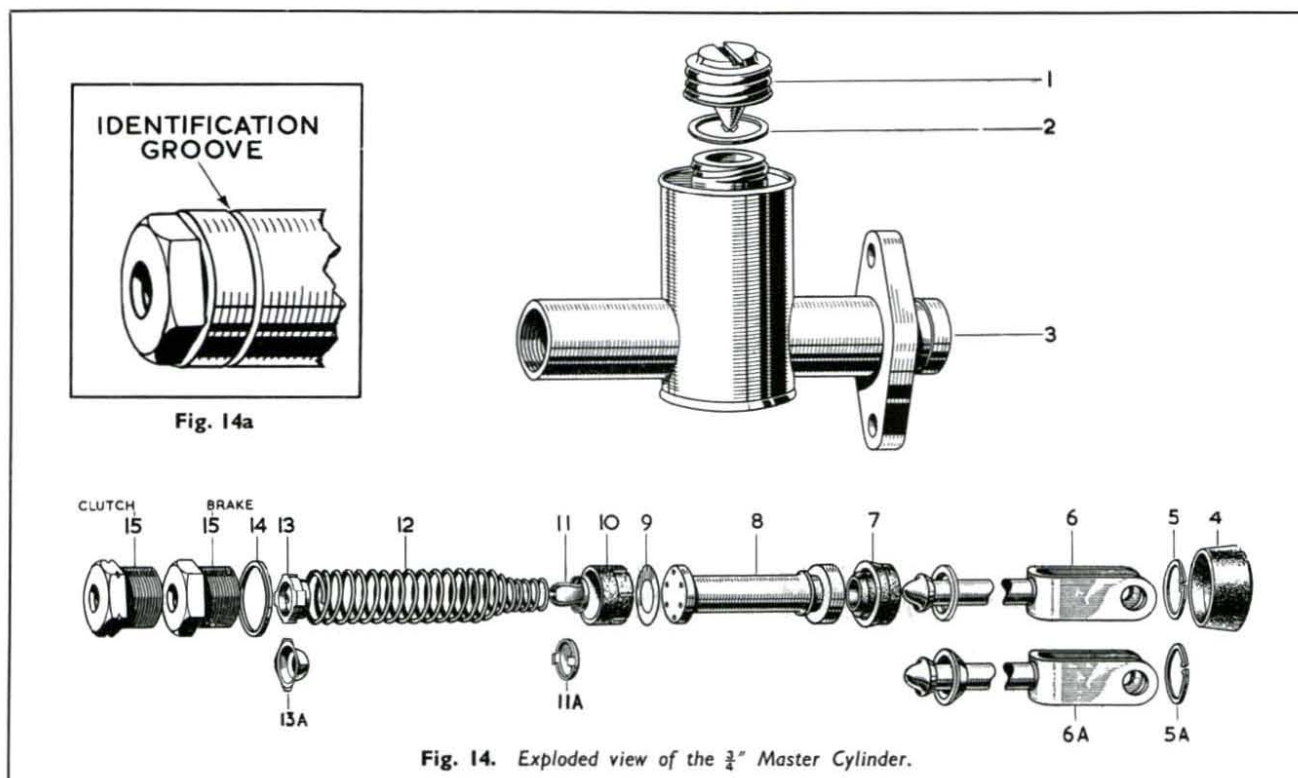

Fig. 14. Exploded view of the $\frac{3}{4}$ " Master Cylinder.

push-rod passes, is fitted on to the barrel to prevent the intrusion of dirt and moisture (the shape of this boot varies with the type of cylinder).

At the end opposite to the push-rod, an end plug (15) screws down against a gasket (14); this plug forms the outlet connection and its inner face provides a seat against which a check-valve assembly (13) is loaded by the spring (with the types of cylinder illustrated on Figs. 12 and 13 the end plug is not fitted, and a rubber washer seats against the end of the cylinder bore. The check valve fitted in this type is illustrated in Fig. 17). The check valve Ref. 13, Fig. 14, is fitted in some units and comprises a rubber body incorporating a metal insert in which a number of holes are drilled. These holes are sealed in one direction by the rubber valve body. In other units the check valve (13A) consists of a dome shaped metal body drilled with a number of holes which are sealed in one direction by a rubber seal secured to its concave side.

PRINCIPLE OF OPERATION (Refer to Fig. 15)

Depressing the brake pedal causes the push-rod to thrust the piston along the bore of the barrel, and the fluid thus displaced lifts the seal away from the check-valve body and passes to the brake wheel cylinders.

Upon removal of the load from the brake pedal, the return spring thrusts the piston back against its stop faster than fluid is able to return from the wheel cylinders; this creates a depression in the master cylinder which draws the edge of the main cup away from the head of the piston and allows fluid from the tank to flow through the feed holes thus uncovered to make up the temporary deficiency.

Meanwhile fluid returning from the wheel cylinders, being under load from the brake shoe pull-off springs, lifts the check-valve away from its seat and re-enters the master cylinder.

When the piston is fully back against its stop, the main cup uncovers a small by-pass port in the barrel, and this allows the release of excess fluid to the tank, thus permitting the pull-off springs to return the brake shoes to the fully "off" position; the by-pass port also compensates for contraction or expansion of the fluid, due to changes in temperature, allowing fluid to flow into or escape from the system. Should this port become blocked any excess fluid would be unable to escape and the brakes would consequently drag.

The purpose of the check-valve is to prevent the re-entry into the master cylinder of fluid pumped into the line during the "bleeding" operation; this ensures a fresh charge of fluid at each stroke of the brake pedal and a complete purge of air from the system.

REMOVING THE BRAKE MASTER-CYLINDER FROM THE VEHICLE

- (1) On some vehicles two very similar master cylinders are used, one to operate the brakes and the other the clutch. With the type illustrated on Fig. 11 the brake cylinder is identified by the fact that the end plug is plain (the plug in the Clutch cylinder being grooved), and in addition each cylinder is etched or bears an identification tag, stating "BRAKE" or "CLUTCH". With the type shown on Fig. 12, the supply tank plug is plain (as illustrated) for the brake master cylinder, but stepped for the clutch.

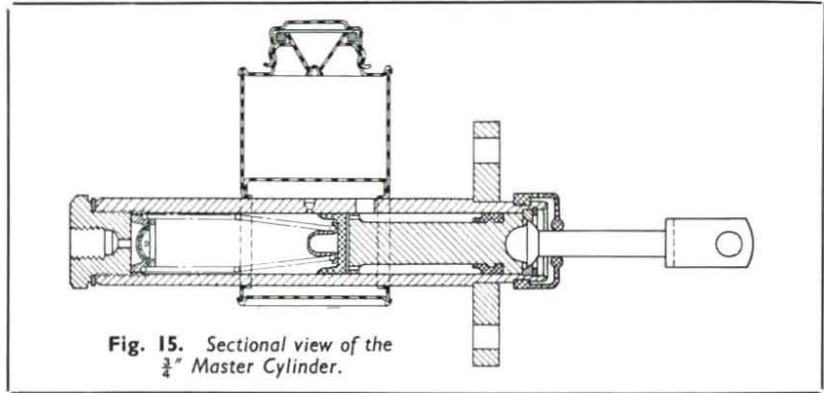

Fig. 15. Sectional view of the $\frac{3}{4}$ " Master Cylinder.

If a twin-bore master cylinder (Fig. 29) is fitted, note particularly which bore is communicated with the clutch slave cylinder, for reference when re-fitting.

- (2) In the instance of cylinders which are fed from a separate supply tank, empty fluid from the tank by attaching a rubber tube to a bleeder screw in one of the wheel cylinders, slacken the screw one complete turn and pump the brake pedal until the tank is empty.
- (3) Brush away any dirt from the pipe connections, disconnect the pipe from the end of the cylinder, and plug the end of the pipe to prevent the entry of dirt and/or the loss of fluid.
- (4) With the type of cylinder shown on Fig. 11 detach the push-rod from the brake-pedal linkage; with the other types the rubber boot may be detached from the end of the cylinder, and the push-rod left attached to the linkage.
- (5) Unscrew the fixing bolts, detach the master cylinder from the vehicle, and drain the remaining fluid from it.

DISMANTLING (Refer to Fig. 14)

- (1) If applicable, detach the rubber boot from the end of the barrel, and move the boot along the push-rod.
- (2) Depress the piston to relieve the spring-load from the circlip (5), remove the circlip and the push-rod (or the piston-stop, if applicable), and withdraw the piston (8), the piston washer, the main cup (10), the spring, the check-valve and the rubber valve washer (if applicable). The end plug (15) (if applicable) should not normally need to be removed from the barrel.
- (3) Remove the secondary cup (7) by stretching it over the end of the piston.

ASSEMBLING (Refer to Fig. 14)

IMPORTANT NOTE

With the type of master cylinder shown on Fig. 14 two types of piston stop and circlip are used and it is essential that the unit bearing an identification groove between the barrel and end plug (see Fig. 14a) be fitted with the circlip and push-rod assembly Fig. 14, Ref. 5 and 6. Furthermore, earlier master cylinders bearing no identification groove on the barrel must be fitted with the circlip and push-rod assembly Fig. 14, Ref. 5a and 6a.

- (1) If previously removed, fit the end-plug (15) and a new gasket (14) (where these parts are applicable). Using the fingers only, stretch the secondary cup (7) on to the piston, with the small end towards the head (*i.e.* drilled end) and with the groove engaging the ridge; gently work round the cup, with the fingers, to ensure correct bedding.

With the types of cylinders shown on Figs. 12 and 13 the secondary cup is to be assembled in the same manner but with the small end of the cup towards the recessed end of the piston (*i.e.* push-rod end).

- (2) Insert the rubber valve washer (if applicable) and push down until it seats squarely against the end face of the cylinder bore.
- (3) Locate the spring retainer (11) in the small end of the return spring (with the earlier types the spring retainer is secured by two tabs which are bent over the end of the spring) and locate the check valve (13) at the large end of the spring.

NOTE: If a twin bore master cylinder (Fig. 29) is being dealt with, note particularly that the bore which communicates with the clutch slave cylinder is **not** fitted with a check valve.



Fig. 16

- (4) Holding the cylinder body so that the outlet is uppermost, insert the spring, valve leading into the barrel. Reversing the cylinder body follow up with the main cup (10) lip leading, taking care not to turn back or buckle the lip of the cup.
- (5) Insert the piston washer (9) so that the curved edge is towards the cup (as on Fig. 16).

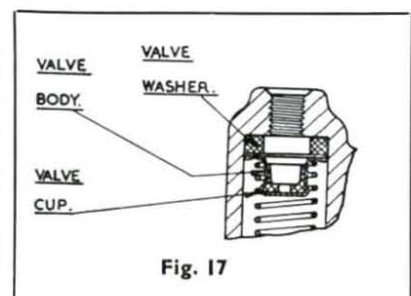

Fig. 17

OVERHAUL INSTRUCTIONS (continued)

- (6) Insert the piston into the barrel, with the drilled head innermost.
- (7) If previously removed, stretch the rubber boot (4) on to the push-rod, with the open end of the boot towards the spherical end of the rod.
- (8) With the type of cylinder shown on Fig. 11, offer up the push-rod to the barrel.
- (9) Push the piston down the bore, locate the piston stop within the barrel and secure it by fitting the circlip (5) at the end of the barrel, it is MOST IMPORTANT that the circlip be fitted correctly in its groove.

RE-FITTING THE BRAKE MASTER-CYLINDER TO THE VEHICLE

- (1) Secure the master cylinder to the vehicle by fitting the fixing bolts and, with the type of cylinder shown on Fig. 11, attach the push-rod to the brake pedal linkage.
- (2) If, with the types of cylinder shown on Figs. 12 and 13, the push-rod was previously removed from the brake pedal linkage, it should now be re-fitted. After ensuring that the rubber boot is in position on the push-rod, insert the end of the rod into the cylinder.
- (3) Stretch the large end of the boot onto the end of the cylinder.
- (4) With the types of master cylinder shown on Figs. 12 and 13, check the brake pedal adjustment (as detailed on page 10); there is no need to do this with the type shown on Fig. 11.
- (5) If the cylinder is of the type which is fed from a separate or a supplementary tank, connect up the pipe from the tank to the top of the cylinder, ensuring that the end of the pipe is first unplugged.
- (6) Fill the supply tank as indicated under ROUTINE ATTENTION, Section 2, re-fit the filler cap (together with its seal, where applicable) and securely tighten.
- (7) Test the master cylinder by pumping the brake pedal several times and allowing it to return unassisted; after one or two applications fluid should flow from the outlet connection.
- (8) Unplug the outlet pipe, and connect it to the end of the cylinder.
NOTE: If a twin-bore master cylinder is being dealt with ensure that the bore without the check valve is connected to the clutch slave cylinder.
- (9) "Bleed" the system as described in Section 5.
NOTE: If a twin-bore master cylinder is being dealt with, refer also to Section 7 for the method of "bleeding" the clutch system.
- (10) Check for leaks by applying a firm pressure to the brake pedal and, whilst maintaining the pressure, inspect the "line" and connections.

DISMANTLING THE FRONT BRAKES

Apply the hand brake and jack up the front wheel of the vehicle. Back off the adjustment and remove the road wheel and brake drum. It will be noted that some brake assemblies are fitted with steady springs see Fig. 18 which hold the shoes against the backplate. If this is the case, disengage the springs by depressing and then turning them. Prior to removing the shoes mark with chalk the position of the pull off springs on the shoes. Pull one of the shoes against the load of the pull off springs and disengage at each end; on releasing the tension on the springs the other brake shoe will fall away.

To remove the wheel cylinders, firstly disconnect the flexible hose at the frame connector and secondly at the wheel cylinder, unscrew the banjo bolts or tube nuts on both wheel cylinders and remove the banjo connections complete with bridge pipe. Finally, unscrew the wheel cylinder retaining nuts or set screws and withdraw the cylinder from the backplate.

IMPORTANT. At no time must oil or grease be allowed in contact with the brake shoe linings.

RELINING THE BRAKE SHOES

When relining the brake shoes, the same make and quality of lining specified for each axle by the vehicle manufacture, must be used throughout, otherwise uneven braking will result despite equal pressure being exerted on all shoes. To enable this to be accomplished in the easiest possible manner, advantage should be taken of our exchange shoe scheme, particulars of which are obtainable from Lockheed Stockists.

ASSEMBLING THE FRONT BRAKES (Refer to Fig. 19)

Offer up the wheel cylinders to the backplate ensuring that the pistons face in the forward direction of rotation of the road wheel and secure by means of the spring washers and nuts or spring washers and set screws. Assemble the bridge pipe and banjo connections or tube nuts on the wheel cylinders and fit the banjo bolts where applicable using new gaskets to ensure pressure tight joints. Screw the flexible hose into the wheel cylinder or banjo connection, using a new gasket, then connect up the other end to the frame connector, and whilst ensuring that the hose is not twisted or kinked secure with the nut and shakeproof washer. Finally connect the fluid pipe by screwing the tube nut into the hose union.

It will be noted that the linings on the brake shoes are shorter than the platforms to which they are attached, the end at which the greater portion of liner platform is exposed is known as the "toe", the other end being called the "heel".

On assembling the brake shoes ensure that the TOE of the shoe is fitted adjacent to the wheel cylinder piston and also that the pull off springs are located in the holes in which they were originally fitted. After the shoes have been assembled fit the Micram adjuster by pulling the toe of the shoe away from the wheel cylinder piston and locate the micram adjuster and mask in the slot provided (see Figs. 6 & 8).

OVERHAUL INSTRUCTIONS (continued)

Finally, where fitted, place the conical steady springs through the shoe web and locate them with the brackets on the backplate by firstly depressing and then turning them. Ensure that all the adjustment is backed off and that the shoes are central, fit the brake drum and road wheel, "bleed" the system and adjust the brakes.

DISMANTLING THE REAR BRAKES

Place chocks under the front wheels and release the handbrake. Jack up the vehicle, remove the road wheel, back off all the available adjustment, disconnect the rod or cable from the wheel cylinder lever then remove the brake drum. It will be noted that some assemblies are fitted with steady springs, see Fig. 18, if

this is the case they may be removed by depressing and then turning.

Prior to removing the shoes mark with chalk the position of the pull off springs on the shoes; pull the trailing shoe against the load of the pull off springs and disengage at each end; on releasing the tension on the springs the other shoe will fall away.

To remove the wheel cylinder firstly disconnect the pipe by unscrewing the tube nut or banjo bolt and remove the rubber boot. Remove the wheel cylinder piston, swing the handbrake lever until the shoulder is clear of the backplate and slide the cylinder casting forward. Finally pivot the cylinder about its forward end and withdraw the rear end from the slot in the backplate; a further rearward movement of the cylinder will now bring its forward end clear of the backplate.

If the assembly is fitted with a heel type adjuster (Fig. 9) remove the tappets and screw the adjusting spindle inwards until it is clear of the threads then withdraw the spindle from the reverse side of the adjuster body.

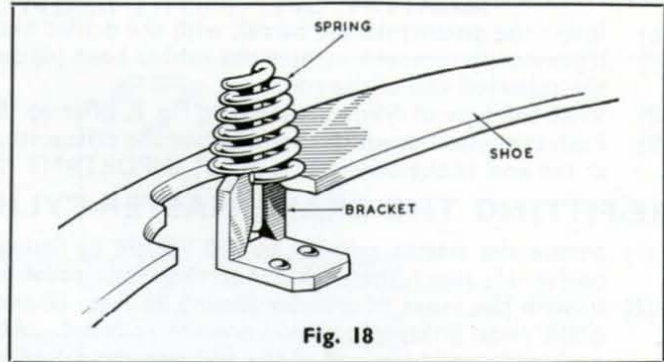

Fig. 18

ASSEMBLING THE REAR BRAKE

Refer to Fig. 20

Offer up the wheel cylinder to the backplate, with the handbrake lever through the slot, and the piston pointing in the direction of forward rotation of the wheel. Engage the forward end of the cylinder in the slot and slide it well forward, taking care to position the lever so that its shoulder clears the backplate. Engage the rear end of the cylinder in the slot and slide it back to hold it in position. Prior to fitting fill the inside of the rubber boot liberally with Lockheed Rubberlube; fit the rubber boot. Connect the pipe to the wheel cylinder by screwing in the tube nut, or if applicable, fitting the banjo bolt together with a new copper gasket. If the assembly is fitted with a heel type adjuster (Fig. 9) and this has been dismantled, before reassembling thoroughly clean all the parts and lightly smear the adjusting spindle threads and the tappets with Lockheed Expander Lubricant. Offer up the threaded portion of the adjusting spindle to the adjuster body and screw fully in; finally slide the tappets into the body ensuring that the tapered portion on each is facing inwards. As this type of brake assembly is of the leading and trailing design, assemble the leading shoe with the TOE adjacent to the wheel cylinder piston, and the trailing shoe with the TOE adjacent to the abutment as shown in Fig. 20. After assembling the shoes ensure that the pull off springs are located in the holes in which they were originally fitted.

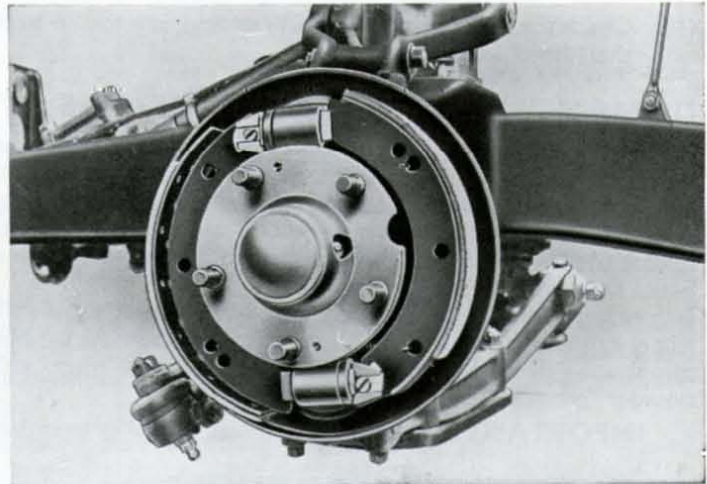

Fig. 19. The Front Brake.

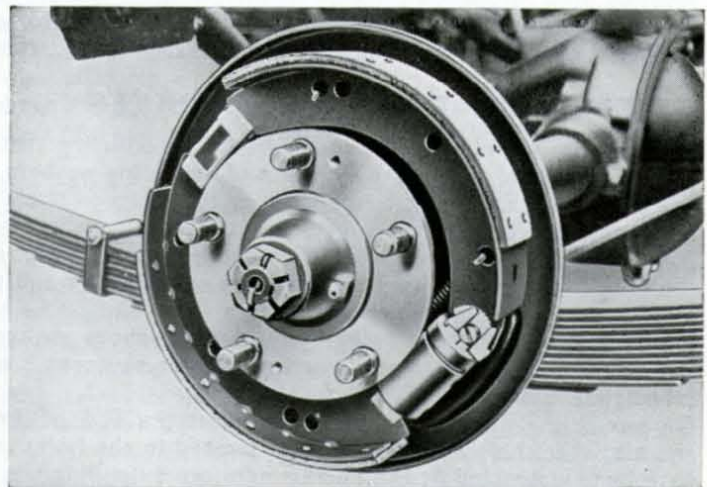
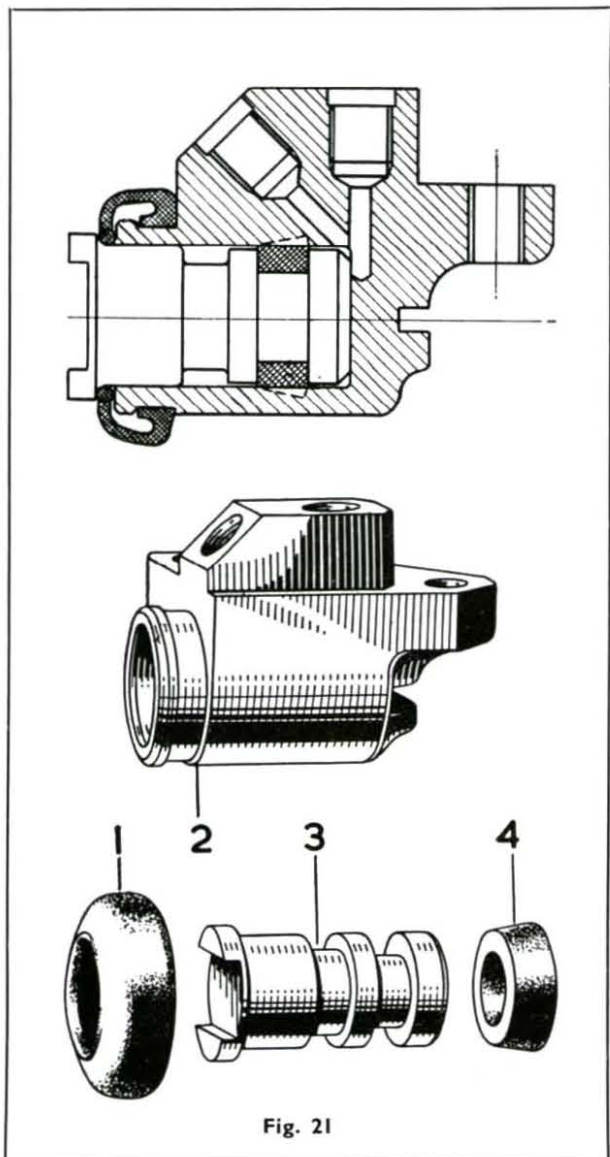

Fig. 20. The Rear Brake.

OVERHAUL INSTRUCTIONS (continued)



Assembling the Rear Brake (continued)

If the brake is fitted with a Micram adjuster, assemble by pulling the toe of the leading shoe away from the wheel cylinder piston and locate the Micram adjuster and mask in the slot provided (see Fig. 6). Finally, if the assembly is fitted with steady springs, assemble by placing the springs through the shoe web and locate them with the brackets on the backplate by depressing and then turning. Ensure that all the adjustment is backed off and that the shoes are centralised, fit the brake drum and road wheel, "bleed" the system and adjust the brakes.

FRONT WHEEL CYLINDER

DESCRIPTION

The type of wheel cylinder used varies according to the vehicle on which it is fitted. In the main there are two types of front wheel cylinders as illustrated in Figs. 21 and 22 these being mounted rigidly on the backplate between the ends of the brake shoes.

The cylinders comprise a body which is bored to accommodate a piston, Ref. 3, Fig. 21, Ref. 1, Fig. 22. In the case of the wheel cylinder Fig. 21, the piston is grooved to carry a taper seal (4) but in the case of the other wheel cylinder a rubber cup (3) is fitted adjacent to the inner face of the piston which is backed by a spring loaded cup filler (4). To prevent the intrusion of foreign matter and moisture the wheel cylinder illustrated in Fig. 21 has a rubber boot (1) fitted to the piston and cylinder body. With the other unit this is accomplished by a metal dust cover welded to the piston and by a rubber seal (2).

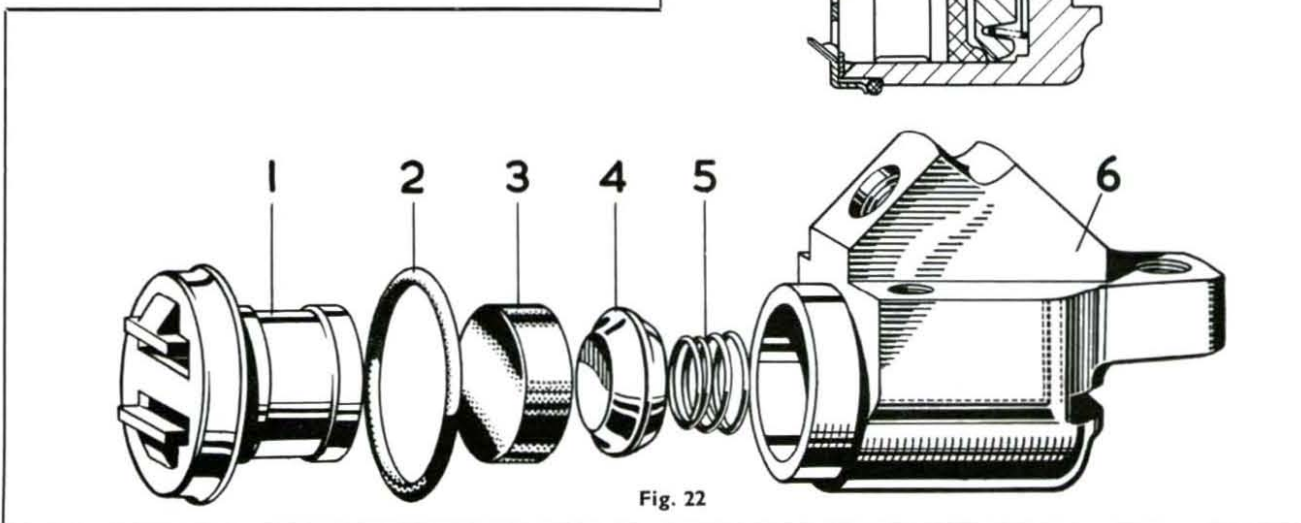

OVERHAUL INSTRUCTIONS (continued)

DISMANTLING

To dismantle the wheel cylinder illustrated in Fig. 21, ease the boot off the body using the fingers only; withdraw the piston (3) and ease the boot (1) and seal (4) off it. **Important.**—When removing the seal ensure that the base of the piston groove is not damaged or fluid leakage past the seat and the inside diameter of the seal will ensue. To dismantle the other wheel cylinder Fig. 22 withdraw the piston, dust cover and seal (1 and 2) complete and apply a **low** air pressure to the fluid connection to blow out the rubber cup (3) and spring loaded cup filler (4 and 5).

ASSEMBLY

In the case of the cylinder illustrated on Fig. 21, ease the rubber seal (4) into the groove on the piston so that the large end is facing away from the slotted end of the piston. Smear the piston with Lockheed "Rubberlube" and offer up to the body, push fully home, taking care to ease the seal past the mouth of the bore. Fill the boot with Lockheed 'Rubberlube' and stretch it into position in the grooves in the piston and cylinder body. With the other unit Fig. 22, place the rubber seal (2) over the inner end of the piston and ease into position against the inner face of the dust cover. Fit the spring (5) in the cup filler (4) and insert the parts, spring leading, into the cylinder bore. Follow this with the rubber cup (3) lip foremost, taking care not to damage or turn back the lip. Offer up the piston to the cylinder body and push fully home.

For refitting the front wheel cylinders to the back-plates see pages 17 and 18.

REAR WHEEL CYLINDER

DESCRIPTION

The type of cylinder used varies according to the vehicle to which it is fitted. In the main there are two types of rear wheel cylinder as illustrated in Figs. 23 and 24, these being mounted and allowed to slide freely in a slot in the backplate.

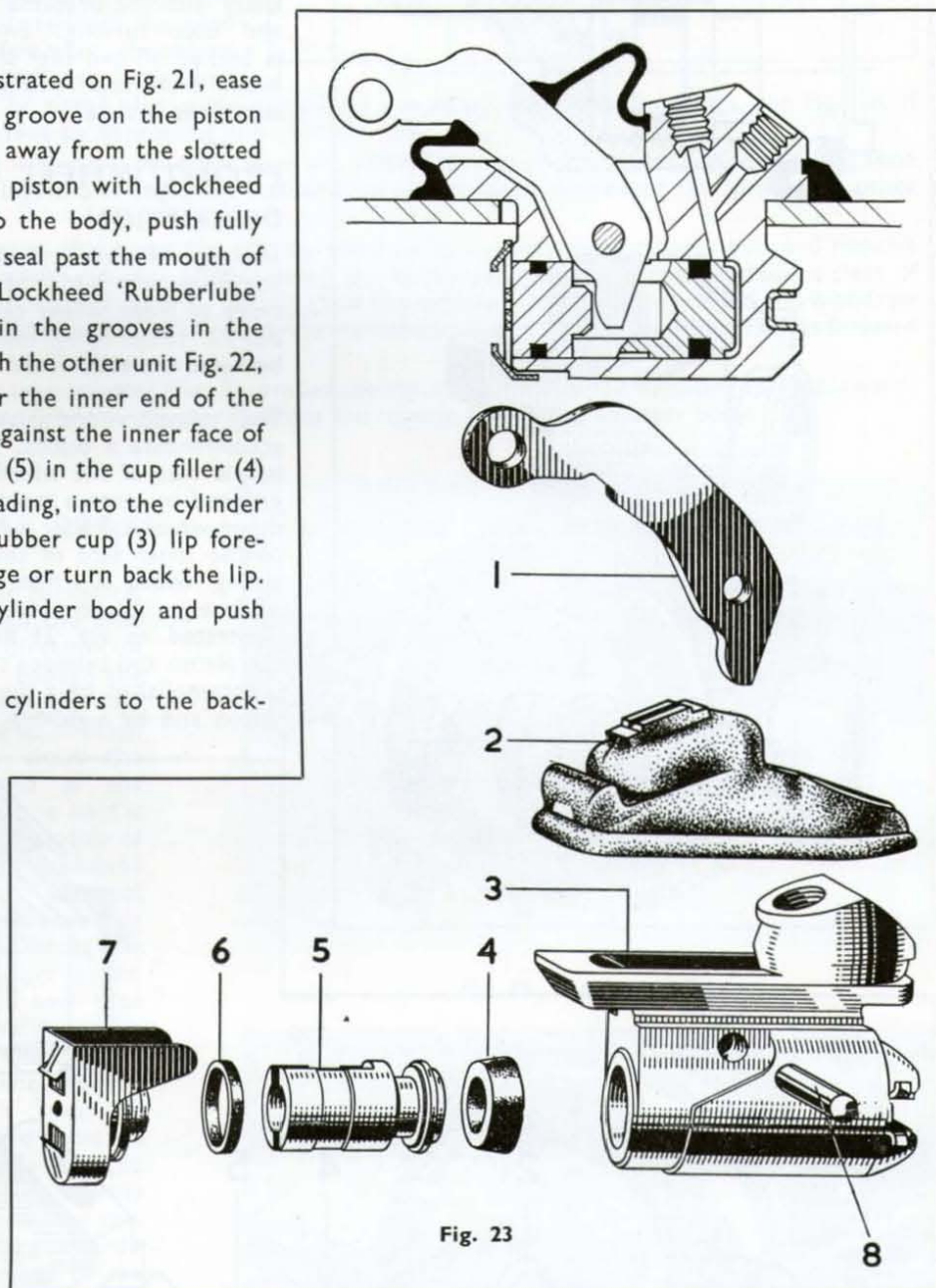

Fig. 23

The cylinders comprise a body which is bored to accommodate two pistons Ref. 5 and 7, Fig. 23, Ref. 7 and 9 Fig. 24. In the case of the wheel cylinder Fig. 23 the pistons are grooved, Ref. 7 to carry a rectangular sectioned rubber seal (6) and Ref. 5 a tapered seal (4). In the case of the other wheel cylinder a rubber cup (6) is fitted adjacent to the inner face of the hydraulic piston which is backed by a spring loaded cup filler (5) and the outer piston (9) is grooved to carry a rectangular sectioned seal (8). The dust covers are welded to the pistons and cannot be removed.

OVERHAUL INSTRUCTIONS (continued)

The pistons are also slotted to receive the heel of a lever (1) which is retained in the body by a pin (8 or 10). When the units are assembled on the backplate they are fitted with a rubber boot (2) through which the lever passes.

When the brake is applied, the hydraulic pressure displaces the inner piston which pushes the outer piston before it, so taking the leading shoe up to the brake drum; upon this shoe contacting the drum, the reaction causes the wheel cylinder body to slide within the slot in which it is housed in the backplate and so apply the trailing shoe. During these operations the position of the lever is undisturbed. See Fig. 25, Ref. 1.

When the handbrake is applied, the linkage pulls on the lever, which pivots about the pin and displaces the outer piston against the leading shoe without disturbing the position of the inner piston; the trailing shoe is again applied by the reactive movement of the wheel cylinder. See Fig. 25, Ref. 2.

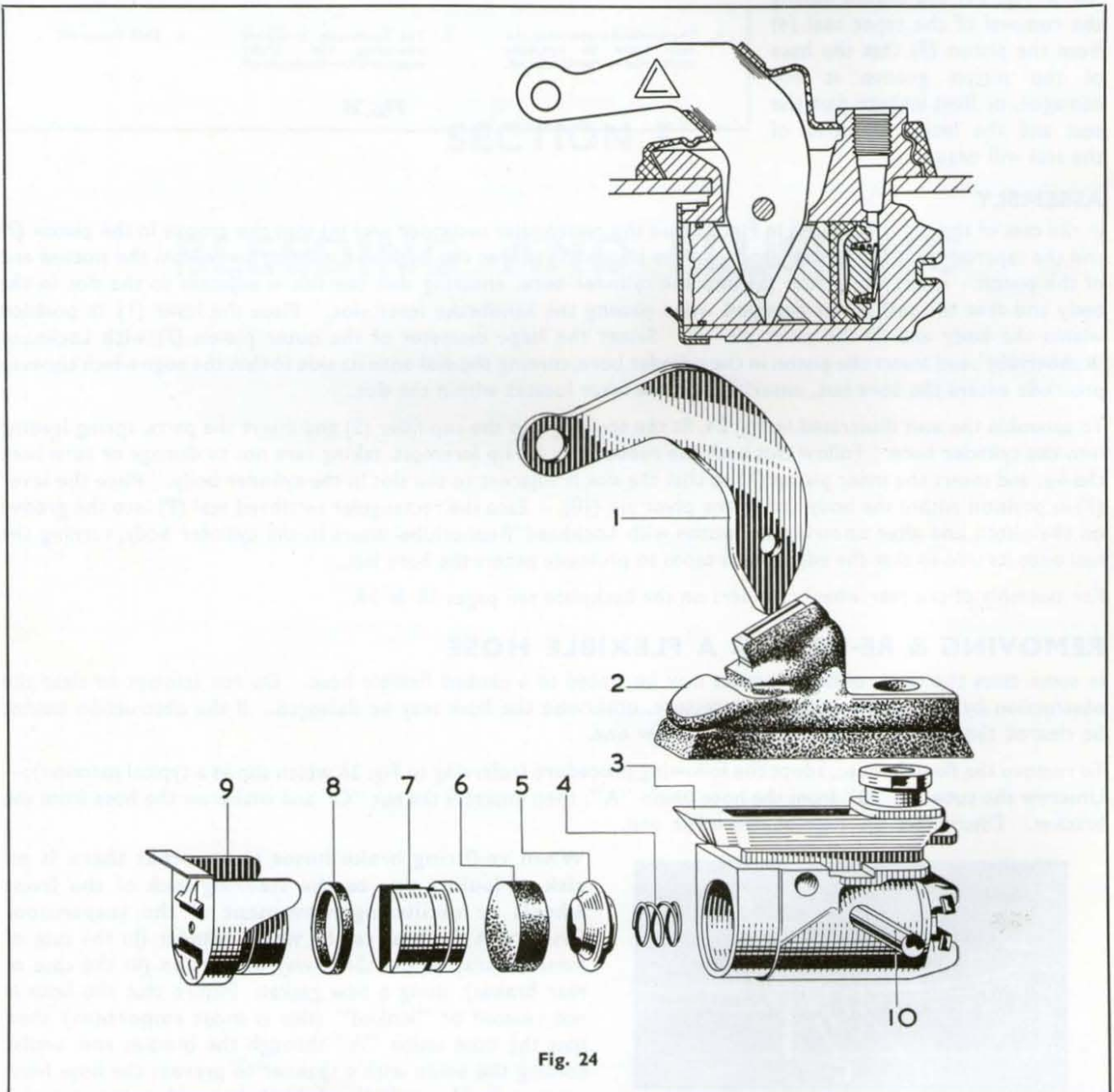
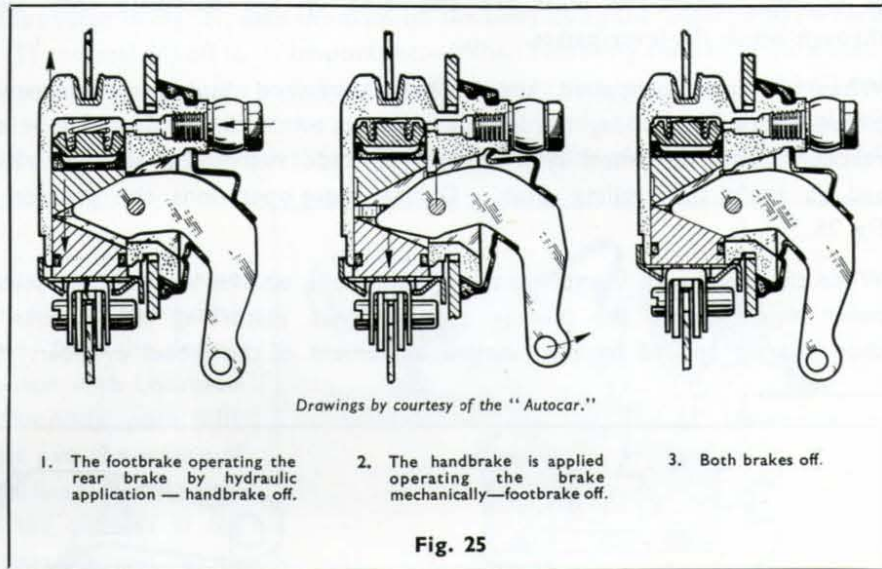

Fig. 24

OVERHAUL INSTRUCTIONS (continued)

DISMANTLING

To dismantle the wheel cylinders illustrated in Fig. 23 and 24, withdraw the outer piston (7 or 9) tap out the pin (8 or 10) and remove the lever (1). Apply a low air pressure at the fluid connection to blow out the inner piston and in the case of the unit shown in Fig. 24 the rubber cup (6) and the spring loaded cup filler (4 and 5). Remove the rubber seals (4, 6 and 8) from the pistons (Ref. 5 and 7, Fig. 23, Ref. 8, Fig. 24) and ensure during the removal of the taper seal (4) from the piston (5) that the base of the piston groove is not damaged, or fluid leakage past the seat and the inside diameter of the seal will ensue.



ASSEMBLY

In the case of the unit illustrated in Fig. 23 ease the rectangular sectioned seal (6) into the groove in the piston (7) and the tapered seal (4) into the groove in the piston (5) so that the large end is facing away from the slotted end of the piston. Insert the piston (5) into the cylinder bore, ensuring that the slot is adjacent to the slot in the body and that the seal is not damaged when passing the handbrake lever slot. Place the lever (1) in position within the body and fit the pivot pin (8). Smear the large diameter of the outer piston (7) with Lockheed 'Rubberlube', and insert the piston in the cylinder bore, turning the seal onto its side so that the edge which tends to protrude enters the bore last, ensuring that the lever locates within the slot.

To assemble the unit illustrated in Fig. 24, fit the spring (4) in the cup filler (5) and insert the parts, spring leading into the cylinder bore. Follow this with the rubber cup (6) lip foremost, taking care not to damage or turn back the lip, and insert the inner piston (7) so that the slot is adjacent to the slot in the cylinder body. Place the lever (1) in position within the body and fit the pivot pin (10). Ease the rectangular sectioned seal (8) into the groove on the piston and after smearing the piston with Lockheed 'Rubberlube' insert in the cylinder body, turning the seal onto its side so that the edge which tends to protrude enters the bore last.

For assembly of the rear wheel cylinders on the backplate see pages 18 & 19.

REMOVING & RE-FITTING A FLEXIBLE HOSE

In some cases the cause of faulty brakes may be traced to a choked flexible hose. Do not attempt to clear the obstruction by any means except air pressure, otherwise the hose may be damaged. If the obstruction cannot be cleared the hose must be replaced by a new one.

To remove the flexible hose, adopt the following procedure (referring to Fig. 26 which shows a typical junction):— Unscrew the tube nut "B" from the hose union "A", then unscrew the nut "C" and withdraw the hose from the bracket. Disconnect the hose at the other end.

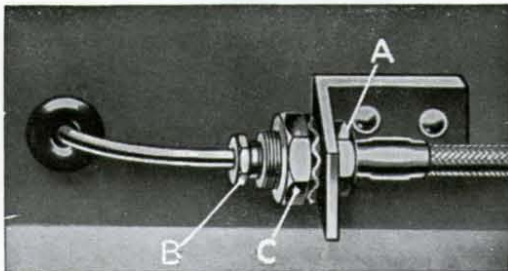

Fig. 26

When re-fitting brake hoses ensure that there is no risk of fouling due to the steering lock of the front wheels or oscillating movement of the suspension.

First attach the hose to the wheel cylinder (in the case of front brakes) or the three-way connection (in the case of rear brakes), using a new gasket. Ensure that the hose is not twisted or "kinked" (this is **most important**) then pass the hose union "A" through the bracket and, whilst holding the union with a spanner to prevent the hose from turning, fit the nut "C" and the shakeproof washer; connect up the pipe by screwing in the tube nut "B".

FLUSHING THE BRAKE SYSTEM

Should the fluid in the system become contaminated, it is important to flush the system. This is done by bleeding the system and flushing it with clean fluid. The procedure is as follows: 1. Disconnect the master cylinder from the booster. 2. Disconnect the brake lines from the master cylinder. 3. Fill the master cylinder with clean fluid. 4. Pump the brake pedal several times to fill the lines. 5. Disconnect the brake line from the wheel cylinder. 6. Allow the fluid to drain into a clean container. 7. Repeat steps 4 through 6 for each wheel cylinder. 8. Reconnect the brake lines and master cylinder. 9. Fill the master cylinder to the proper level. 10. Pump the brake pedal several times to bleed the system. 11. Check the fluid level and top up if necessary.

SECTION 5

BLEEDING AND FLUSHING

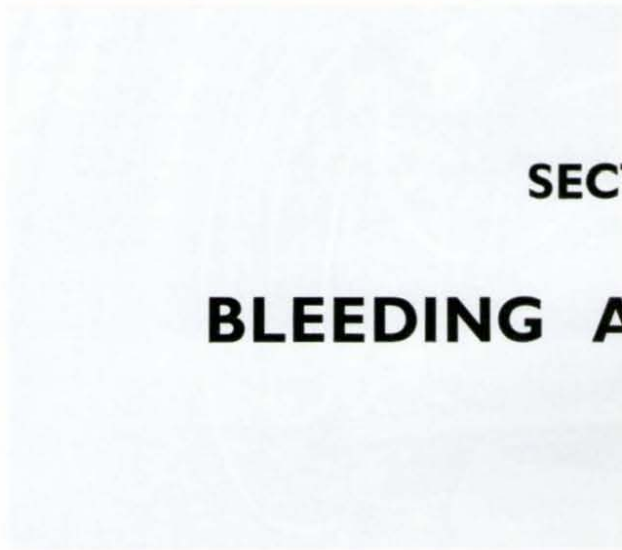

The first step in flushing the brake system is to disconnect the master cylinder from the booster. This is done by removing the two bolts that hold the master cylinder to the booster. Once disconnected, the master cylinder can be removed from the vehicle. The next step is to disconnect the brake lines from the master cylinder. This is done by removing the nuts that hold the lines to the master cylinder. Once disconnected, the lines can be removed from the vehicle. The master cylinder and lines are then filled with clean fluid. The brake pedal is pumped several times to fill the lines. The brake line is then disconnected from the wheel cylinder. The fluid is allowed to drain into a clean container. This process is repeated for each wheel cylinder. Finally, the brake lines and master cylinder are reconnected. The master cylinder is filled to the proper level. The brake pedal is pumped several times to bleed the system. The fluid level is checked and topped up if necessary.

BLEEDING THE SYSTEM (FIG. 2-3)

1. Disconnect the master cylinder from the booster. 2. Disconnect the brake lines from the master cylinder. 3. Fill the master cylinder with clean fluid. 4. Pump the brake pedal several times to fill the lines. 5. Disconnect the brake line from the wheel cylinder. 6. Allow the fluid to drain into a clean container. 7. Repeat steps 4 through 6 for each wheel cylinder. 8. Reconnect the brake lines and master cylinder. 9. Fill the master cylinder to the proper level. 10. Pump the brake pedal several times to bleed the system. 11. Check the fluid level and top up if necessary.

12. Disconnect the master cylinder from the booster. 13. Disconnect the brake lines from the master cylinder. 14. Fill the master cylinder with clean fluid. 15. Pump the brake pedal several times to fill the lines. 16. Disconnect the brake line from the wheel cylinder. 17. Allow the fluid to drain into a clean container. 18. Repeat steps 14 through 16 for each wheel cylinder. 19. Reconnect the brake lines and master cylinder. 20. Fill the master cylinder to the proper level. 21. Pump the brake pedal several times to bleed the system. 22. Check the fluid level and top up if necessary.

23. Disconnect the master cylinder from the booster. 24. Disconnect the brake lines from the master cylinder. 25. Fill the master cylinder with clean fluid. 26. Pump the brake pedal several times to fill the lines. 27. Disconnect the brake line from the wheel cylinder. 28. Allow the fluid to drain into a clean container. 29. Repeat steps 24 through 26 for each wheel cylinder. 30. Reconnect the brake lines and master cylinder. 31. Fill the master cylinder to the proper level. 32. Pump the brake pedal several times to bleed the system. 33. Check the fluid level and top up if necessary.

34. Disconnect the master cylinder from the booster. 35. Disconnect the brake lines from the master cylinder. 36. Fill the master cylinder with clean fluid. 37. Pump the brake pedal several times to fill the lines. 38. Disconnect the brake line from the wheel cylinder. 39. Allow the fluid to drain into a clean container. 40. Repeat steps 34 through 36 for each wheel cylinder. 41. Reconnect the brake lines and master cylinder. 42. Fill the master cylinder to the proper level. 43. Pump the brake pedal several times to bleed the system. 44. Check the fluid level and top up if necessary.

45. Disconnect the master cylinder from the booster. 46. Disconnect the brake lines from the master cylinder. 47. Fill the master cylinder with clean fluid. 48. Pump the brake pedal several times to fill the lines. 49. Disconnect the brake line from the wheel cylinder. 50. Allow the fluid to drain into a clean container. 51. Repeat steps 44 through 46 for each wheel cylinder. 52. Reconnect the brake lines and master cylinder. 53. Fill the master cylinder to the proper level. 54. Pump the brake pedal several times to bleed the system. 55. Check the fluid level and top up if necessary.

FLUSHING THE BRAKE SYSTEM

Should the fluid in the system become thick or "gummy" after long service, or after a vehicle has been laid up for some time, the system should be drained, flushed and refilled. It is recommended that this should be carried out at intervals not exceeding eighteen months or twenty-four thousand miles, whichever occurs first. The system should also be flushed if it has become contaminated by the use of spurious fluid.

Pump all fluid out of the hydraulic system through the bleeder screw of each wheel cylinder in turn. Connect one end of a rubber tube to the bleeder screw, allowing the other end to fall into a container, unscrew one complete turn and pump the brake pedal by depressing it quickly and allowing it to return without assistance. Repeat, with a pause in between each operation, until no more fluid is expelled. Discard the fluid extracted.

Fill the supply tank with new brake fluid and flush the system by pumping as described above.

Keep the supply tank replenished until clean fluid flows from each bleed screw.

Where possible, remove the supply tank and pour off any remaining spirit.

Refill with new Lockheed Super 105 Brake Fluid to Spec. S.A.E. J1703 and "bleed" the system.

Note: If the system has become contaminated by the use of mineral oil, etc., the above process may not prove effective. It is recommended that the various units, including the pipe line, should be dismantled and thoroughly cleaned and that all rubber parts, including flexible hoses, should be renewed. The contaminated fluid should be destroyed immediately.

FLUSHING THE CLUTCH SYSTEM

The clutch system should also be cleaned in the same manner, remembering that the bleeder screw on the slave cylinder should be closed at the end of each downward stroke of the clutch pedal. (See bleeding of the clutch system on page 30).

"BLEEDING" THE SYSTEM (Figs. 27 & 28)

"Bleeding" the system—or expelling air—is not a routine operation and should be necessary only when some portion of the hydraulic equipment has been disconnected or when fluid has been drained off. (The method detailed below is not suitable for a hydraulic clutch operating system: in such an instance refer to page 30).

- (1) Fill the supply tank with Lockheed Super 105 Brake Fluid to Spec. S.A.E. J1703 and keep at least a quarter full throughout the operation. Otherwise, air will be drawn in, necessitating a fresh start.
- (2) Attach a rubber tube to the bleeder screw on one of the wheel cylinders and allow the free end to be submerged in a little brake fluid in a clean glass jar. Open the bleeder screw one complete turn.
- (3) Depress the brake pedal slowly, allowing it to return unassisted, repeating this pumping action with a slight pause between each operation. Watch the flow of fluid in the jar and when all air bubbles cease to appear, hold the pedal down firmly and securely tighten the bleeder screw.
- (4) Repeat at all wheel cylinders. On completion of the "bleeding" procedure, replenish the master cylinder tank as indicated in Section 2.

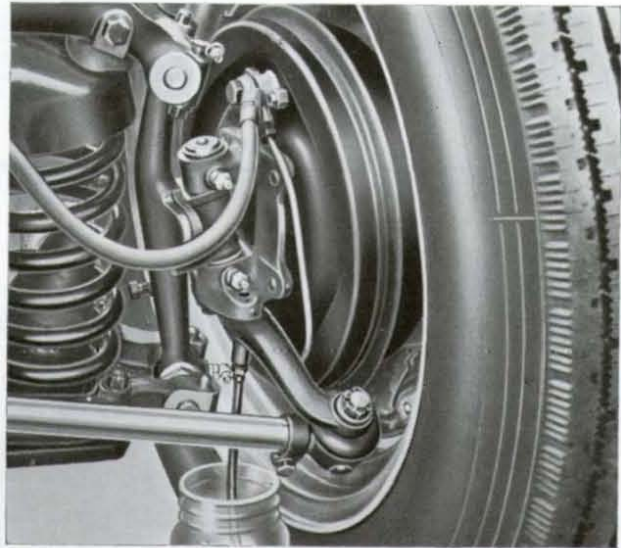

Fig. 27. Bleeding front wheel cylinders.

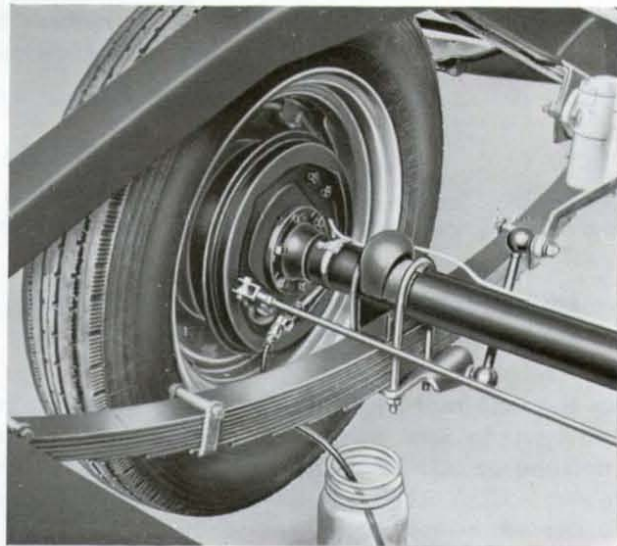

Fig. 28. Bleeding rear wheel cylinder.

Note: We do not recommend the re-use of fluid which has been bled from the hydraulic system.

SECTION 6

FAULT FINDING

1. PEDAL TRAVEL EXCESSIVE

(Requires Pumping).

- (a) Brake Shoes require adjusting or re-lining if adjustment is already at a maximum.
- (b) Master Cylinder push rod requires adjusting. (Excessive push-rod clearance).
- (c) Master Cylinder requires replenishing.
- (d) Leakage past main cup in Master Cylinder.

2. PEDAL FEELS SPRINGY

- (a) Linings not "bedded-in".
- (b) Brakes drums weak or cracked.
- (c) Master Cylinder fixing loose.

3. PEDAL FEELS SPONGY

- (a) Leakage past main cup in Master Cylinder.
- (b) Master Cylinder secondary cup worn. (Air bubbles rise in supply tank).
- (c) Leak at one or more points in system.
- (d) Brakes not properly bled.

4. BRAKES INEFFICIENT

- (a) Linings not "bedded-in".
- (b) Linings greasy.
- (c) Linings incorrect type.

5. BRAKES DRAG

- (a) Shoes over adjusted.
- (b) Shoe pull-off springs weak or broken.
- (c) Pedal spring weak or broken.
- (d) Pedal to push rod adjustment incorrect.
- (e) Handbrake mechanism seized.
- (f) Wheel Cylinder piston seized.
- (g) Supply tank overfilled or vent hole in filler cap blocked.
- (h) Master Cylinder by-pass port choked.
- (i) Handbrake cables over adjusted.

6. BRAKES REMAIN ON

- (a) Shoes over adjusted.
- (b) Handbrake over adjusted.
- (c) Pedal to push rod adjustment incorrect.
- (d) Master Cylinder and/or wheel cylinder cups swollen, due to contamination with mineral oil or spurious fluid.

7. UNBALANCED BRAKING

- (a) Greasy linings.
- (b) Distorted drums.
- (c) Front spring broken or loose at anchorage
- (d) Tyres unevenly inflated.
- (e) Brake backplate loose on axle.
- (f) Worn steering connections.
- (g) Worn spring shackles.
- (h) Different grades of linings fitted

DESCRIPTION

The hydraulic clutch system is a type of clutch system that uses hydraulic pressure to operate the clutch. It consists of a clutch master cylinder, a clutch slave cylinder, and a clutch line. The clutch master cylinder is located in the engine compartment and is connected to the clutch slave cylinder by a clutch line. The clutch slave cylinder is located in the clutch housing and is connected to the clutch pedal. When the clutch pedal is depressed, the clutch master cylinder pushes hydraulic fluid through the clutch line to the clutch slave cylinder, which then pushes the clutch fork and release bearing to disengage the clutch.

SECTION 7

THE HYDRAULIC CLUTCH SYSTEM

The hydraulic clutch system is a type of clutch system that uses hydraulic pressure to operate the clutch. It consists of a clutch master cylinder, a clutch slave cylinder, and a clutch line. The clutch master cylinder is located in the engine compartment and is connected to the clutch slave cylinder by a clutch line. The clutch slave cylinder is located in the clutch housing and is connected to the clutch pedal. When the clutch pedal is depressed, the clutch master cylinder pushes hydraulic fluid through the clutch line to the clutch slave cylinder, which then pushes the clutch fork and release bearing to disengage the clutch.

CLUTCH SLAVE CYLINDER
DESCRIPTION
The clutch slave cylinder is a type of hydraulic cylinder that is used to operate the clutch. It is located in the clutch housing and is connected to the clutch pedal. When the clutch pedal is depressed, the clutch master cylinder pushes hydraulic fluid through the clutch line to the clutch slave cylinder, which then pushes the clutch fork and release bearing to disengage the clutch.

DESCRIPTION

In the main there are two types of master cylinders used for clutch actuation shown in Figs. 29 and 30, both having the trap valve omitted to ensure that when the foot is off the clutch pedal, there shall be no pressure in the "line" between the master cylinder and slave cylinder which might otherwise cause clutch slip.

The twin bore master cylinder shown in Fig. 29 caters for the operation of both the brake and the clutch system. Apart from the fact that no check valve is fitted in the clutch bore, each cylinder is identical. This layout is shown in Fig. 32.

An alternative layout shown in Fig. 33 utilises the master cylinder illustrated in Fig. 30 which is again similar in construction to the brake master cylinder Fig. 14 except that the check valve is omitted. The clutch cylinder may be identified externally by the grooved end plug Ref. 15, Fig. 14, by etching or by an identification tag stating "CLUTCH".

A further type of master cylinder used is similar to the type shown on Fig. 12, and this is identified by the stepped supply tank plug.

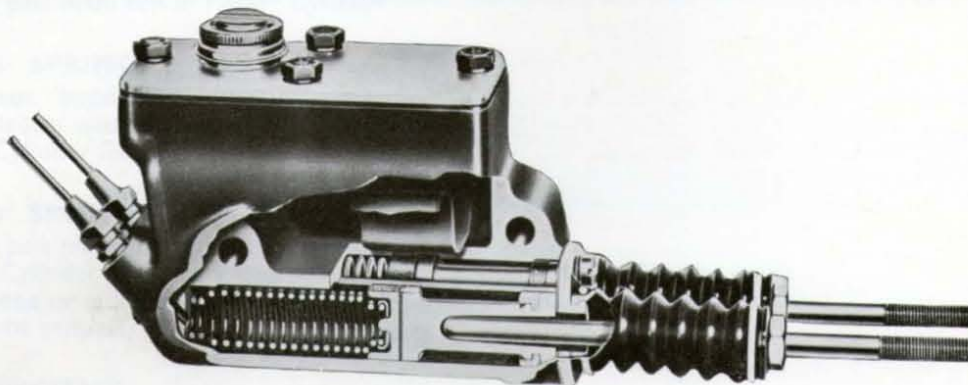

Fig. 29

REMOVING THE CLUTCH MASTER CYLINDER

Where a separate master cylinder is used for operating the clutch system, removal is effected in the same manner as that detailed on page 16 for the brake master cylinder. However, if the type illustrated on Fig. 29 is fitted, note particularly before removal which bore is communicated with the clutch slave cylinder.

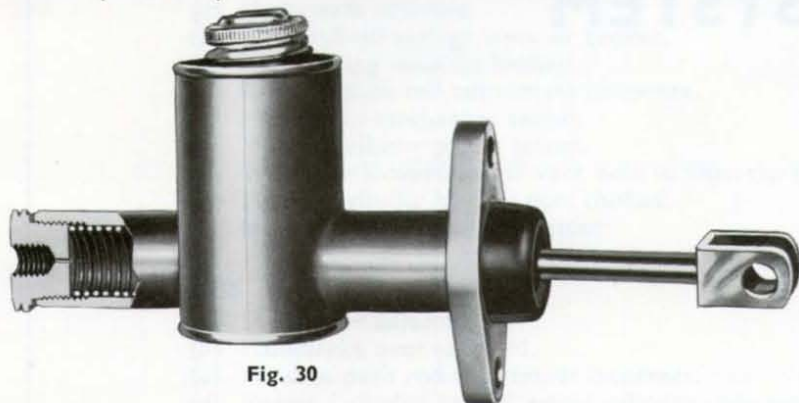

Fig. 30

DISMANTLING, ASSEMBLING AND RE-FITTING

The instructions given for the normal type of master cylinder (see page 16) apply. It is to be remembered that when assembling the unit shown in Fig. 29 that the bore which operates the clutch slave cylinder is not fitted with a check valve. The pistons in this unit are retained by a boot fixing plate to which the rubber boots are attached.

CLUTCH SLAVE CYLINDER

DESCRIPTION

The clutch slave cylinder (refer to Fig. 31) consists of a body (7) which incorporates two threaded connections and is bored to accommodate a piston (4) against the inner face of which a rubber cup (3) is loaded by a cup filler (2) and a spring (1); the travel of the piston is limited by a circlip (5) fitted in a groove at the end of the bore. A rubber boot (6), through which a push-rod passes, is fitted on to the body to prevent the intrusion of dirt or moisture.

One of the connections in the body receives a pipe from the clutch master cylinder, whilst the other is fitted with a bleeder screw.

REMOVAL FROM VEHICLE AND DISMANTLING

To remove from the vehicle, disconnect the pipe, detach the rubber boot from the body and remove the fixing screws; leave the push-rod attached to the vehicle. If the boot is not being renewed it may be left on the push-rod. Remove the circlip (5) from the end of the bore and apply a low air pressure to the open connection to expel the piston (4) and the other parts; remove the bleeder screw.

THE HYDRAULIC CLUTCH SYSTEM

(continued)

ASSEMBLING & RE-FITTING TO THE VEHICLE

Prior to assembly, smear all internal parts and the bore of the body with Rubberlube.

Fit the spring (1) in the cup filler (2) and insert these parts, spring innermost, into the bore of the body (7). Follow up with the cup (3), lip leading, taking care not to turn back or buckle the lip; then insert the piston (4), flat face innermost, and fit the circlip (5) into the groove at the end of the bore.

Fit the rubber boot (6) on the push-rod if removed previously and offer up the slave cylinder to the vehicle with the push-rod entering the bore. Secure the cylinder with the fixing screws and stretch the large end of the boot into the groove on the body.

Fit into their respective connections the bleeder screw and the pipe from the clutch master cylinder.

"Bleed" the clutch system as described on page 30.

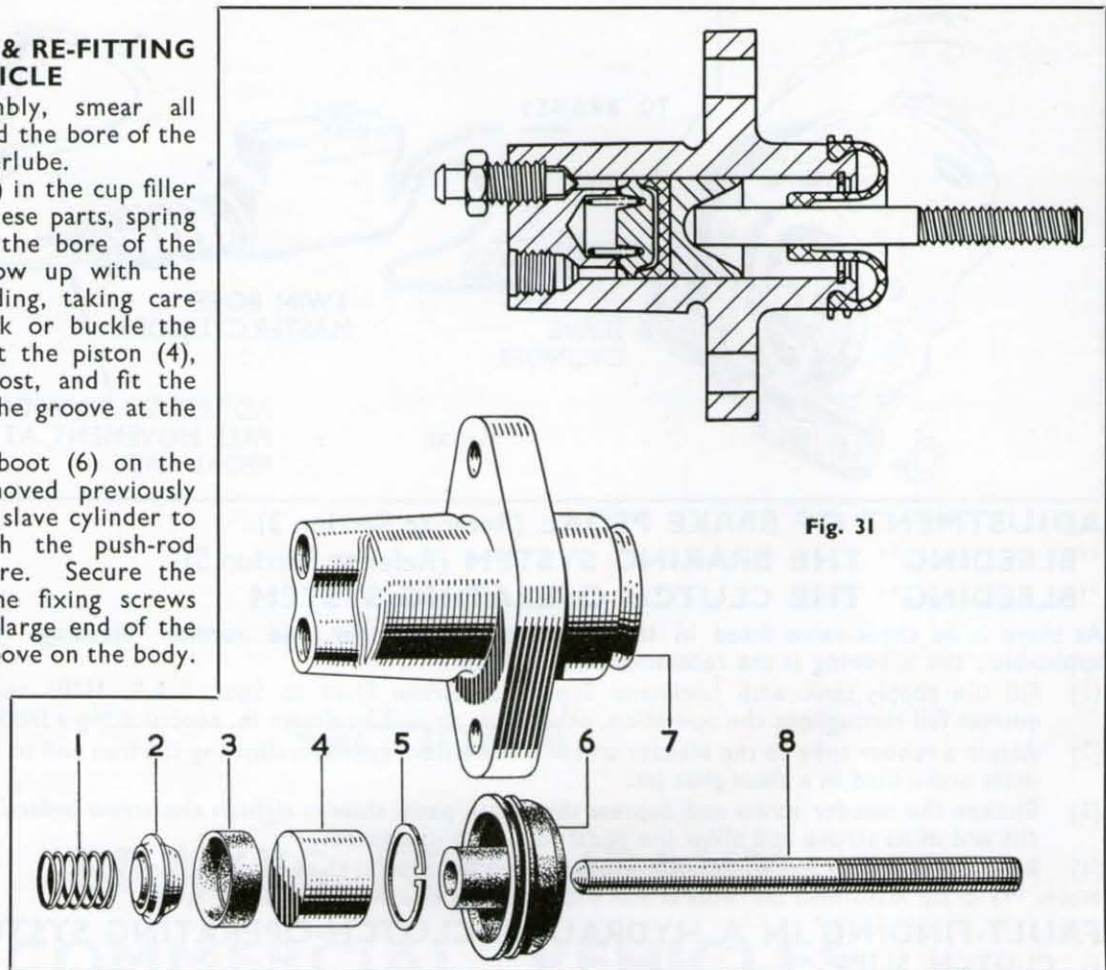

Fig. 31

ADJUSTMENT OF THE CLUTCH PEDAL

In order to ensure the complete return of the piston in the clutch master cylinder, it is necessary to provide a minimum clearance between the piston and the push-rod which operates it, when the piston is fully back against its stop. This is important since if the piston is prevented from returning fully the lip of the cup will cover the by-pass port and prevent the escape of the excess fluid drawn into the cylinder during the return stroke of the piston; the clutch slave cylinder would thus remain extended causing the clutch to slip.

With some master cylinders, the clearance is automatically obtained (Fig. 30) therefore, a check should be made to ensure that the clutch pedal is not being fouled thus preventing the maximum return of the pedal. With other units the clearance is achieved by manual adjustment of the push-rod (Fig. 29) this being easily distinguishable by the push-rod which is threaded and fitted with a locknut. Using the following method set the clearance to give $\frac{5}{32}$ " free movement at the clutch pedal.

Slacken the locknut (A Fig. 32 Refers) and reset the length of the push-rod extension until the pedal can be depressed the correct amount before the piston begins to move. Re-tighten the locknut.

ADJUSTMENT OF THE SLAVE CYLINDER PUSH-ROD

To ensure the correct relationship between the release lever plate and release bearing two types of system are employed:—

- (1) Where there is clearance between the release lever plate and the release bearing, with the clutch fully engaged. Periodic adjustment is necessary with this type, the method of which is described below.
- (2) Where there is light rubbing contact between the release lever plate and the release bearing, with the clutch fully engaged. No adjustment of this type is required.

The systems can be easily distinguished; system (1) has provision for adjustment of the slave cylinder push rod, whereas system (2) has not.

To adjust the slave cylinder push rod (B. Fig. 32 Refers) slacken the locknut and ensuring that the slave cylinder piston is at the bottom of the bore, adjust to provide $\frac{1}{16}$ " clearance between the release bearing and the release lever plate. Re-tighten the locknut.

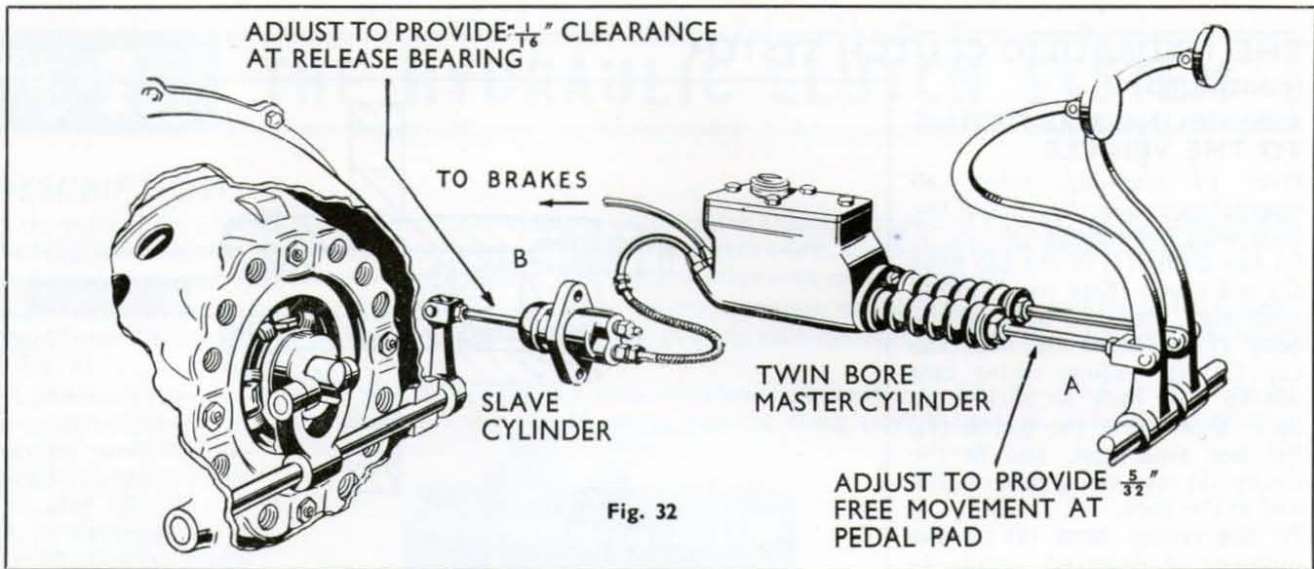

Fig. 32

ADJUSTMENT OF BRAKE PEDAL (Refer to Section 3)

"BLEEDING" THE BRAKING SYSTEM (Refer to Section 5)

"BLEEDING" THE CLUTCH OPERATING SYSTEM

As there is no check-valve fitted in the clutch master cylinder, the normal "bleeding" procedure is not applicable; the following is the recommended method.

- (1) Fill the supply tank with Lockheed Super 105 Brake Fluid to Spec. S.A.E. J1703 and keep at least a quarter full throughout the operation, otherwise, air will be drawn in, necessitating a fresh start.
- (2) Attach a rubber tube to the bleeder screw on the slave cylinder, allowing the free end to be submerged in a little brake fluid in a clean glass jar.
- (3) Slacken the bleeder screw and depress the clutch pedal slowly; tighten the screw before the pedal reaches the end of its stroke and allow the pedal to return unassisted.
- (4) Repeat (3) until air bubbles cease to appear from the tube in the end of the jar.

Note: We do not recommend the re-use of fluid which has been bled from the hydraulic system.

FAULT-FINDING IN A HYDRAULIC CLUTCH-OPERATING SYSTEM

1. CLUTCH SLIPS

- (a) Failure to adjust at the clutch slave-cylinder push-rod* to compensate for loss of release-bearing clearance resulting from wear of the driven-plate facings (the method is given on page 29).
- (b) Seized piston in clutch slave cylinder.
- (c) Fluid reservoir filler cap vent hole blocked.

* In some instances the push-rod is non-adjustable and, in such a case, the driven-plate facing wear is automatically compensated for.

2. CLUTCH DRAGS or FAILS TO RELEASE

- (a) Air in clutch system ("bleed" as described above).
- (b) Bad external leak between the clutch master cylinder and the clutch slave cylinder.
- (c) Excessive clearance between the release-bearing and the release-lever plate.
- (d) Leakage past main cup in Master Cylinder.

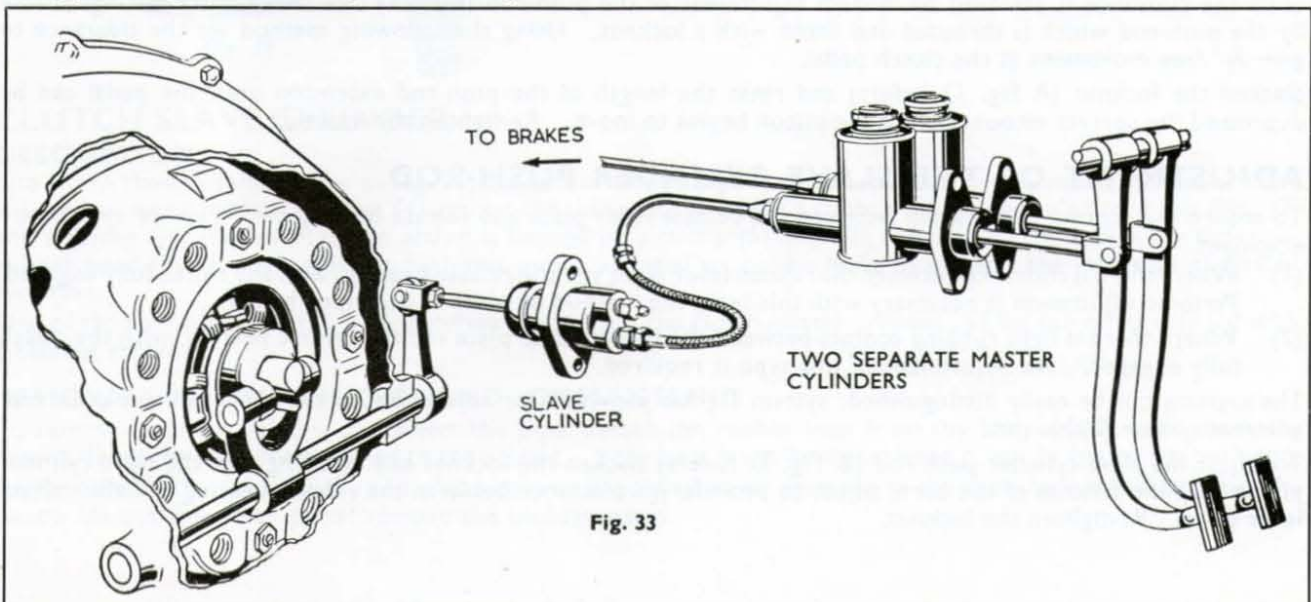

Fig. 33

SECTION 8

**BRAKES FOR HEAVY
COMMERCIAL VEHICLES**

SECTION 8

BRAKES FOR HEAVY COMMERCIAL VEHICLES

The heavy vehicle equipment (shown diagrammatically on Fig. 34) consists of a Master Cylinder similar to that used on the light vehicles; two double-ended internal wheel cylinders on each backplate, which operate the two leading shoe front brakes; a transverse wheel cylinder and bisector on the rearward edge of each rear backplate, together with an adjuster on the forward edge, to operate the leading and trailing rear brakes, and the "line" consisting of tubing, flexible hoses and unions interposed between the Master Cylinder and the wheel cylinders.

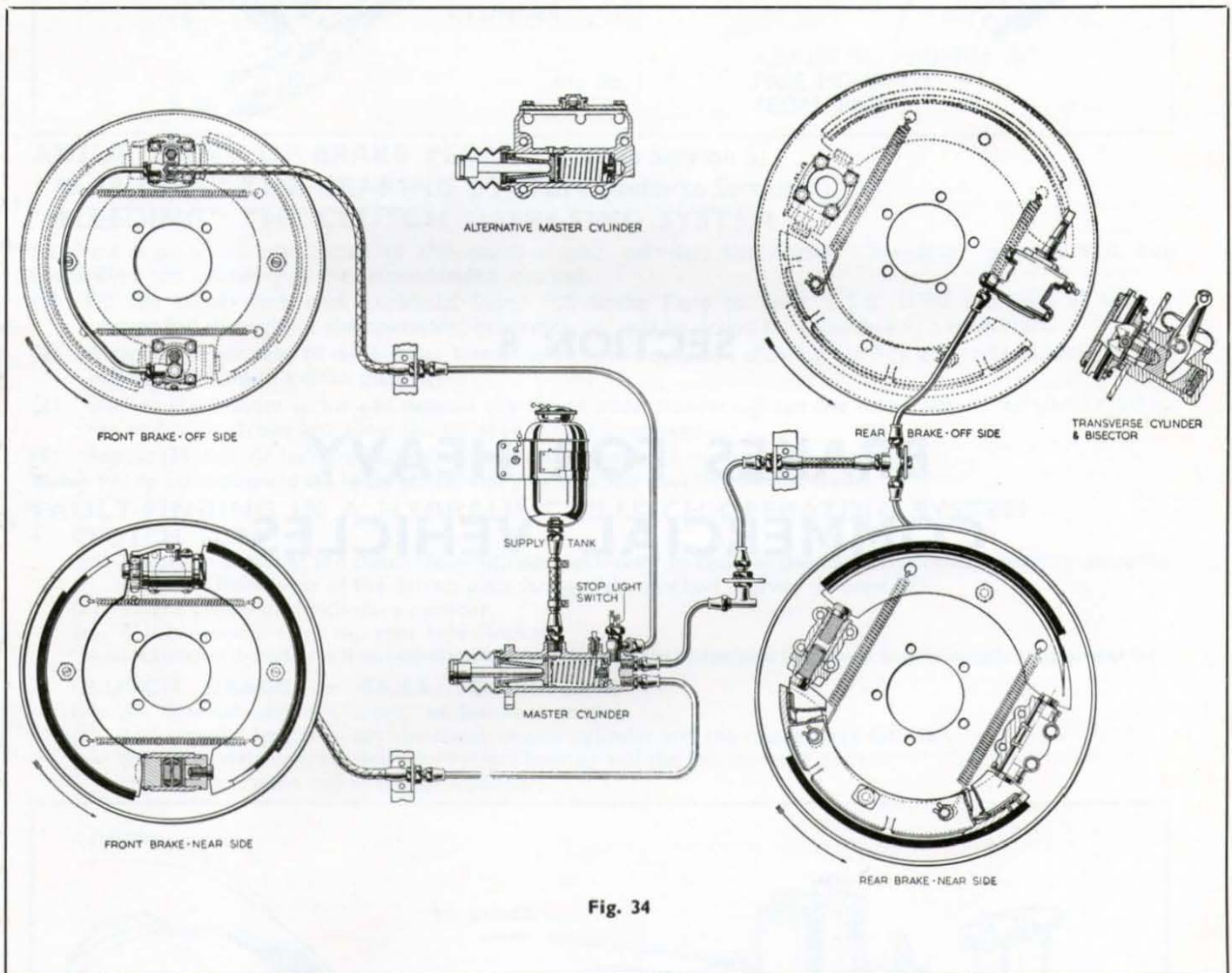

Fig. 34

“BLEEDING” THE SYSTEM (Figs. 35 and 36)

- (1) Fill the supply tank with Lockheed Super 105 Brake Fluid to Spec. S.A.E. J1703 and keep at least a quarter full throughout the operation, otherwise air will be drawn in, necessitating a fresh start.
- (2) If the master cylinder used in the system is of a type fitted with a bleeder screw, commence at this unit. Slacken the bleeder screw, depress the brake pedal slowly by hand and, whilst FLUID issues and before the pedal reaches the end of its stroke, tighten the bleeder screw securely.
- (3) Attach a rubber tube to the bleeder screw on one of the wheel cylinders and allow the free end to be submerged in a little fluid in a clean glass jar. Open the bleeder screw one complete turn.



Fig. 35
Bleeding front wheel cylinders.

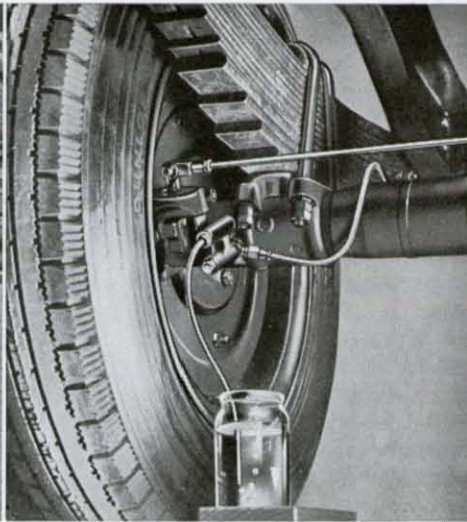

Fig. 36
Bleeding rear wheel cylinders.



Fig. 37
Adjusting front brake shoes

- (4) Depress the brake pedal slowly, allowing it to return unassisted, repeating this pumping action with a slight pause between each operation. Watch the flow of fluid in the jar and when all air bubbles cease to appear, hold the pedal down firmly and securely tighten the bleeder screw.
- (5) Repeat at all wheel cylinders.

Note: We do not recommend the re-use of fluid which has been bled from the hydraulic system.

BRAKE SHOE ADJUSTMENT—Front Wheels

Jack up one wheel until it is free to revolve and centralize the shoes by applying the brake. Swing the dust cover away to expose one hole in the backplate and insert a cranked lever or screwdriver not exceeding 6" in length. (Fig. 37) engaging it in the slot on the adjuster end cap; turn the end cap in a clockwise direction relative to the wheel cylinder, until the brake shoe bears against the drum. Back off the adjustment the least possible amount to enable the wheel to revolve freely. Repeat these operations on the second wheel cylinder. Adjust the opposite front wheel cylinders in a similar manner. **Close the dust covers.**

BRAKE SHOE ADJUSTMENT—Rear Wheels

Place chocks under the front wheels, release the handbrake and jack up one rear wheel until it is free to revolve. Turn the wheel in a forward direction and apply the footbrake to position the shoes in the drum. Proceed as for the front wheels noting that there is only one adjuster for each rear wheel (Fig. 38).

After approximately 15,000 miles running, it may be found that the lining on the plain (upper) shoe has worn to such an extent that normal adjustment will no longer be sufficient; in such a case, lever the shoe out of the adjuster screw and turn the screw outwards two complete turns.

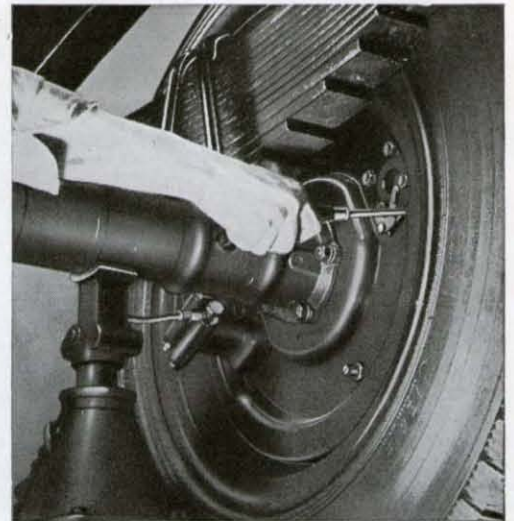

Fig. 38
Adjusting rear brake shoes.

FRONT BRAKE ASSEMBLY

The front brake assembly (Fig. 39) is carried on a backplate (3) to which two wheel cylinders (1, 5) are rigidly mounted inside the brake drum and diametrically opposed between the brake shoe tips. Each cylinder has two axially opposed pistons, one provided with the adjuster, acting on the toe of the brake shoe (7), while the second serves as an abutment for the heel of the other shoe (4). When the direction of rotation is reversed, the function of both pistons and shoe tips is inter-changed, thereby providing a two leading shoe brake in either direction.

The brake shoes are retained by two pull-off springs (2, 6) and are guided in the vertical fore-and-aft plane by two adjustable steady pins fitted on the backplate (3).

REMOVING THE FRONT WHEEL CYLINDERS AND BRAKE SHOES

Jack up the vehicle, back off all the available adjustment on each wheel cylinder, and remove the wheel and brake drum. Remove the brake shoes by levering one shoe against the tension of each pull-off spring in turn, firstly at the toe with a view to disengaging this from the slot in the wheel cylinder adjusting screw and secondly at the heel so as to enable the slot in the solid portion of the opposite wheel cylinder to be cleared. On releasing the tension of the pull-off springs, the second shoe will fall away. Remove the flexible hose. Unscrew the banjo bolts on both cylinders and remove the banjo adaptors complete with the bridge pipe. Remove the set screws and spring washers securing the wheel cylinders to the backplate and withdraw the cylinders.

RE-FITTING THE FRONT WHEEL CYLINDERS AND BRAKE SHOES

Offer up the wheel cylinders in turn to the backplate, locating each cylinder so that the clicker spring is towards the outside with the end cap over the adjusting hole in the backplate. Secure each cylinder with spring washers, locking plates and set screws and back off all adjustment. Assemble the banjo adaptors, complete with the bridge pipe to the inlet boss on each cylinder and insert the banjo bolts making pressure tight joints with new gaskets. Screw the flexible hose, with a new gasket, into place and tighten down. Attach the opposite end of the hose to the frame connector with spring washer and nut and connect the pipe to the hose end by means of the tube nut. Refit the brake shoes, with the pull-off springs behind the shoe webs; it will be noticed that, at one end of each shoe, there is no lining, in each case this end is to be nearer to the adjuster end-cap on the respective wheel-cylinder. Ensure that all the adjustment is backed-off and that the brake shoes are central, fit the brake drum and the road wheel, "bleed" the system and adjust the brakes.

Fig. 40

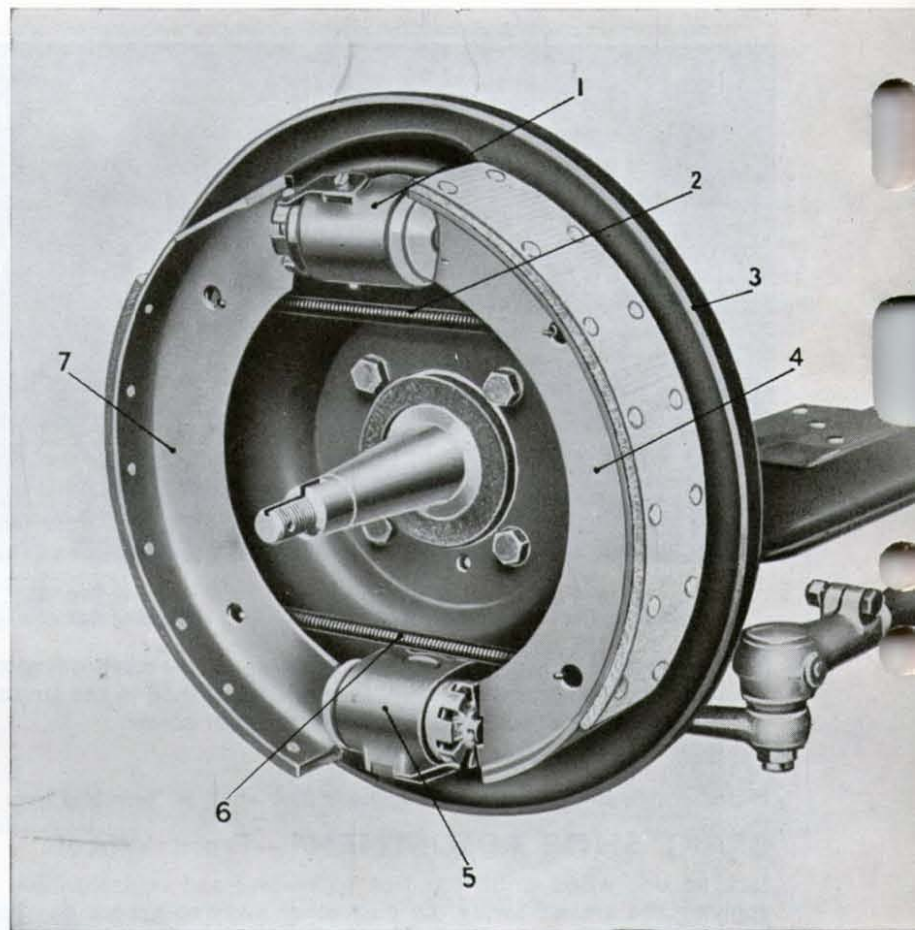
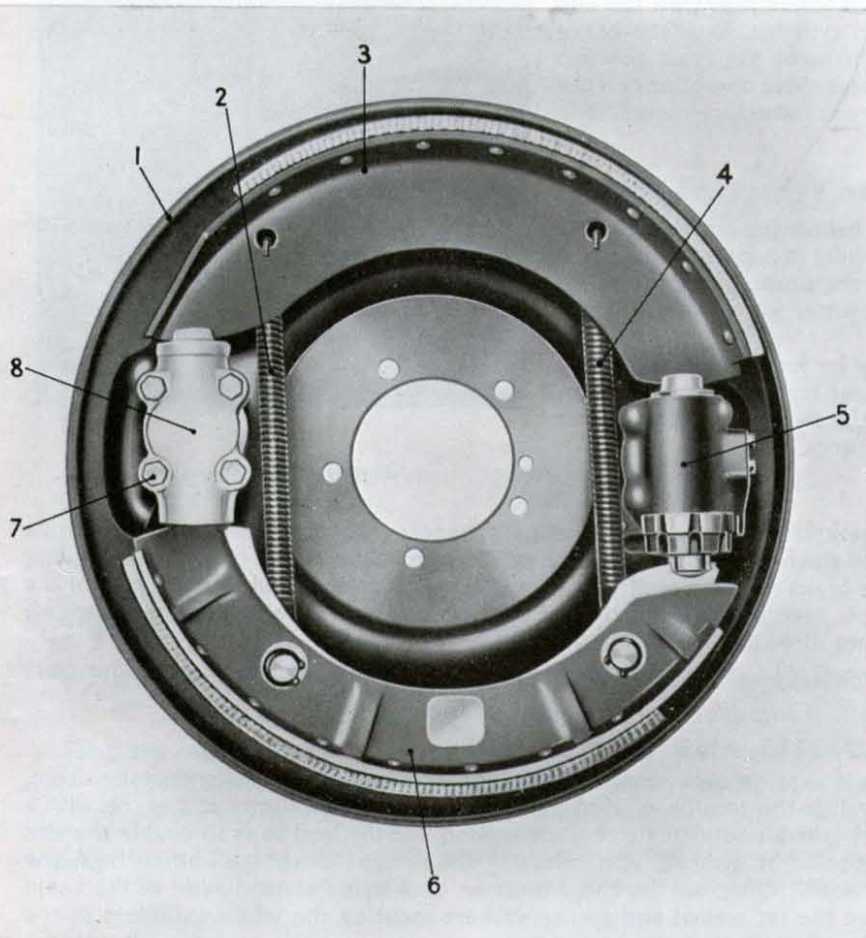

Fig. 39



REAR BRAKE ASSEMBLY

The rear brake assembly (see Fig. 40) consists of a backplate (1) on the outer face of which are rigidly attached an adjuster (5), towards its forward edge, and a bisector (8), at its rearward edge: the latter being operated by a transverse wheel cylinder (see Fig. 49), behind the backplate and secured by four set screws (7) which pass through the bisector and backplate and are screwed into the cylinder body.

Between the upper screw of the adjuster and the upper tappet of the bisector is a single webbed brake shoe (3), while between the lower adjusting screw and tappet is a brake shoe and carrier (6).

The upper shoe (3) and shoe and carrier assembly (6) are retained by two pull-off springs (2, 4), hooked at one end directly into the upper shoe behind the web and, at the other end, on to anchor pins on the carrier assembly. In addition the shoes are guided in the vertical fore-and-aft plane by two adjustable pins carried on the backplate.

REMOVING THE REAR WHEEL CYLINDERS AND BRAKE SHOES

Place chocks under the front wheels, jack up the back axle and loosen the nuts securing the rear wheels on one side of the vehicle. Release the handbrake and remove the wheels. Back off all the available adjustment at the brake shoe adjuster unit and remove the clevis pin which links the brake rod to the lever on the transverse wheel cylinder. Remove the screws securing the drum to the hub and withdraw the drum, evenly and equally. During this operation, tap the drum periodically with a hide faced hammer to ensure that it is not binding on the shoes. Lever the upper shoe upwards and out of the slot in the adjusting screw, then lever the brake shoe and carrier outwards and out of the slot in the other adjusting screw. The shoes can now be uncoupled from the pull-off springs and removed. Remove the set screws and spring washers securing the adjuster to the backplate and withdraw the adjuster. Disconnect the pipe from the transverse wheel cylinder and remove the set screws and spring washers securing the bisector to the transverse cylinder; withdraw both units from the backplate. Dismantling and assembling instructions for the adjuster, the bisector and the transverse wheel cylinder are given on pages 36, 37 and 38 respectively.

RE-FITTING THE REAR WHEEL CYLINDER AND BRAKE SHOES

Mount the adjuster on the forward face of the backplate with the end cap in line with the adjusting hole, secure by means of spring washers and set screws and back-off all adjustment. Offer up the transverse wheel cylinder to the rear of the backplate, with the lever pointing in the direction specified in the vehicle manufacturers' handbook. Locate the bisector from the front over the spigot on the cylinder, with its abutment ring downwards, and secure by means of spring washers, locking plates and set screws.

Hook the pull-off springs on to the anchor pins in the brake shoe and carrier so that the hooks on the opposite ends of the springs face outwards. Offer up the shoe and carrier to the bisector and adjuster ensuring that the end of the shoe at which there is no lining is nearer to the adjuster. Hook the upper shoe on to the pull-off springs and lever it into the slots in the bisector and adjuster so that the end of the shoe at which there is no lining is nearer to the bisector.

Centralize the shoes, as near as possible, in relation to the outer rim of the backplate.

Measure the distance from the centre of the liner on the brake shoe and carrier assembly and the inner face of the backplate flange; this dimension should be approx. $\frac{3}{4}$ ". If the dimension is more, turn the adjuster end cap in a clockwise direction to bring the adjusting screw (Fig. 45, Ref. A) outwards until this dimension is obtained. One complete turn of the adjuster end cap moves the adjusting screw approximately .070" outwards. This automatically moves the adjusting screw (Fig. 45, Ref. F) a similar amount.

Measure the distance from the centre of the liner on the upper brake shoe and the inner face of the backplate flange; this dimension should be $\frac{3}{4}$ ". If it is more, lever the brake shoe out of the slot in the adjusting screw (Fig. 45, Ref. F) and, using a lever, turn the screw outwards (left-hand thread) until this dimension is obtained. Back off the adjustment by turning the end cap and offer up the brake drum. If the drum will not pass over the shoes they may be out of the central position and should be tapped to allow the drum to be fitted. Fit the pressure pipe to the wheel cylinder, using new gaskets on the banjo bolt, re-connect the pull-rod to the lever in the cylinder, "bleed" the system and adjust the brakes.

NOTE.—The tool used for turning the adjuster should not exceed 6" in length.

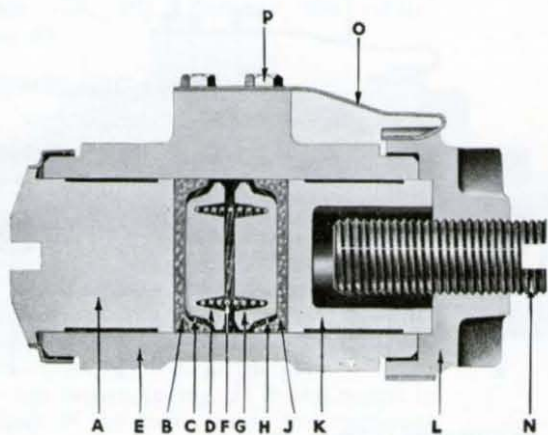

Fig. 41

The cylinder body is formed with a lug to which a clicker spring (O) is secured by set screws (P). The free end of the spring engages one of the serrations on the outer diameter of the end cap (L) to provide security against vibration.

FRONT BRAKE CYLINDER

The front wheel cylinder (see Figs. 41 and 42) consists of a body (E) in one end of which is a solid piston (A) formed with a flange, which carries a dust cover and butts against the cylinder. The outer end of this piston is slotted to provide a location for the heel of the brake shoe. In the opposite end of the cylinder body is another piston (K), deeply recessed on its outer face. This piston butts against a threaded end cap (L) which controls an adjusting screw (N), clearance for which is provided by the recess in the piston. The outer end of the adjusting screw is slotted to serve as a location for the toe of its respective brake shoe and to prevent the screw from rotating when assembled.

Each piston is backed by a rubber cup (B, J), a crown spring (C, H) and a cup filler (D, G), these latter being separated and retained in close contact, each with its respective crown spring and cup, by a return spring (F).

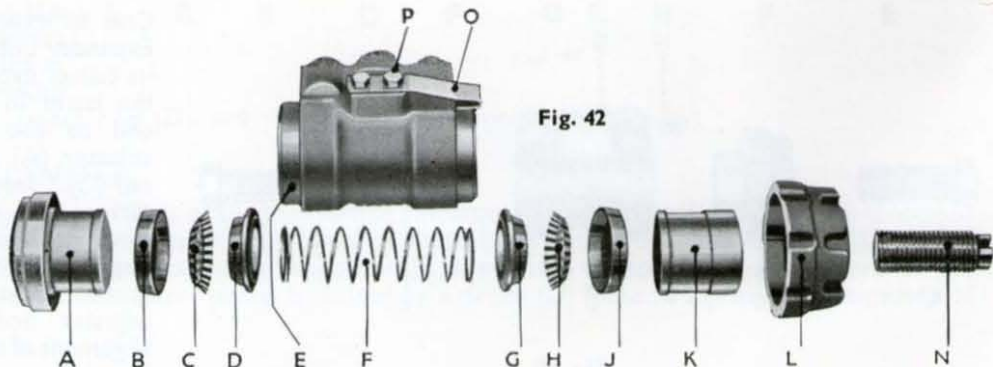

Fig. 42

DISMANTLING

Remove the end cap (L) complete with adjusting screw (N) and unscrew the adjuster. Insert a rod, of wood or soft metal, into the recess in the piston and push the internal parts out of the cylinder (E).

ASSEMBLING

Smear the piston (A) with Lockheed 'Rubberlube' and insert to its fullest extent in the bore of the cylinder (E) from the opposite end to the clicker spring (O). Stand the cylinder in an upright position, using the piston as a base, and insert a rubber cup (B), lip outwards, followed by a crown spring (C) to conform to the cup shape. Locate the return spring (F) between the two cup fillers (D, G) and place one cup filler on the crown spring already assembled. Position the second crown spring (H) and rubber cup (J) over the uppermost cup filler, lip downwards, followed by the flat face of the piston (K) and press the whole into the cylinder, taking care not to damage or turn back the lip of the second cup.

Screw the adjuster (N) to its fullest extent into the end cap (L). Slide the end cap over the end of the cylinder, with the adjusting screw (N) housed in the recess in the piston, at the same time pick up the free end of the clicker spring in one of the serrations on the end cap.

Another type of wheel cylinder (see Figs. 43 and 44) which is similar in most respects, has a disc shaped piston (Q), a spring leaf (P), and is fitted with two sealing rings (S).

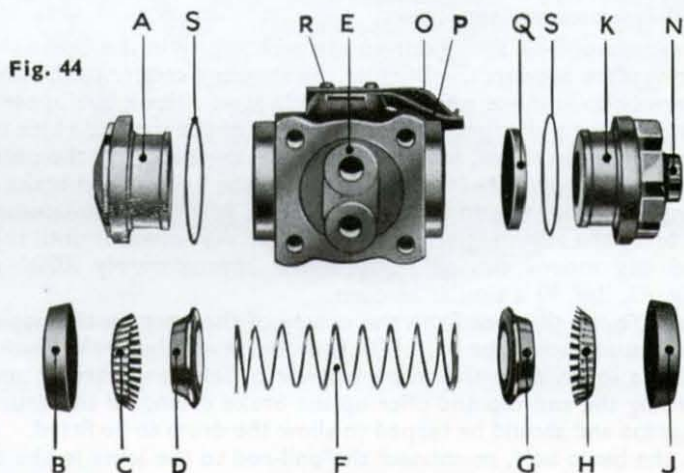
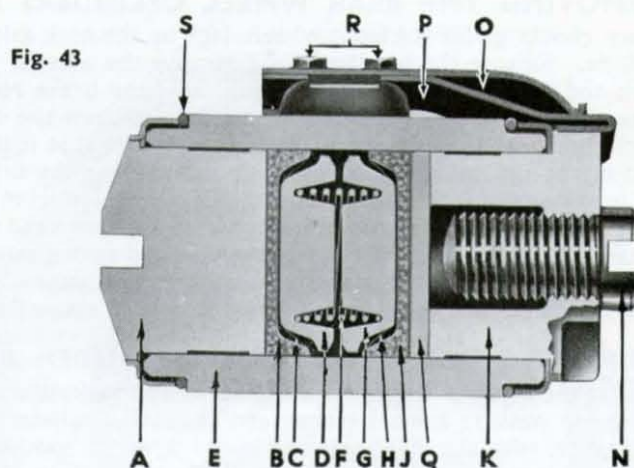

REAR BRAKE ADJUSTER

The adjuster (see Figs. 45 and 46) consists of a body (D) which houses at one end, an adjuster cap (C) and, at the other end, an adjuster sleeve (E). Rotary motion of the end cap is transmitted to the sleeve through engaging dogs formed on the adjoining faces of the components. The end cap and sleeve are threaded internally to receive two adjuster screws, the one (A) in the end cap has a right hand thread, while the other (F), in the sleeve has a left hand thread. Secured by set screws (G) to a lug formed on the body, is a clicker spring (H) which engages one of the serrations on the end cap to provide security against vibration; in some cases a spring leaf is fitted in addition.

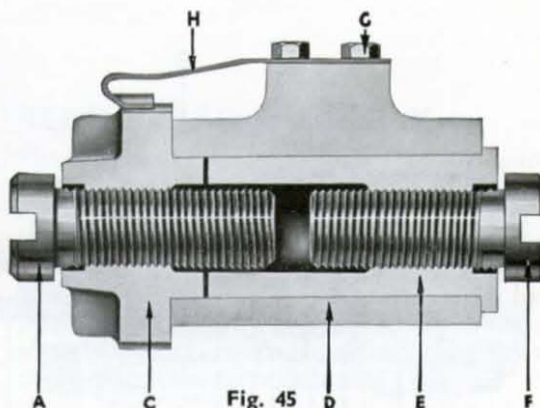

DISMANTLING

Remove the end cap (C) from the body and unscrew the adjuster (A). Withdraw the adjuster sleeve (E) and unscrew the adjuster (F).

ASSEMBLING

Coat all internal parts liberally with Lockheed Expander Lubricant. Screw the adjuster (F) to its fullest extent, into the sleeve (E) and insert the latter in the body (D) from the opposite end to the clicker spring (H). Screw the adjuster (A) to its fullest extent, into the end cap (C). Insert the end cap in the body, taking care to pick up the clicker spring in one of the serrations and, at the same time, engaging the dogs, so that the slots in the adjuster screws are as near parallel to the location face on the adjuster body as is possible. Correct the alignment of the adjuster screw slots by unscrewing each one an equal amount.

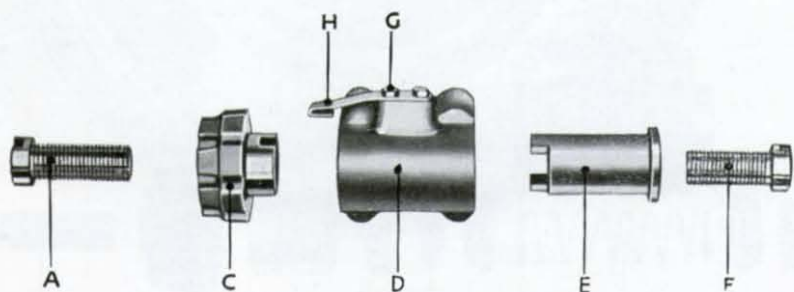

Fig. 46

THE BISECTOR

The bisector (see Figs. 47 and 48) consists of a body (C) housing two opposing tappets (B, F) having inclined inner faces and slotted outer faces. Located in a groove in the tappet (B) which controls the single webbed brake shoe, is a circlip (A) which limits the inward stroke of that tappet, while around the second tappet (F), and secured to the bisector body by counter sunk screws (E), is an abutment ring (D) to take the thrust of the double webbed brake shoe in the forward direction of rotation. The tappets are retained and prevented from rotating by two set screws (G).

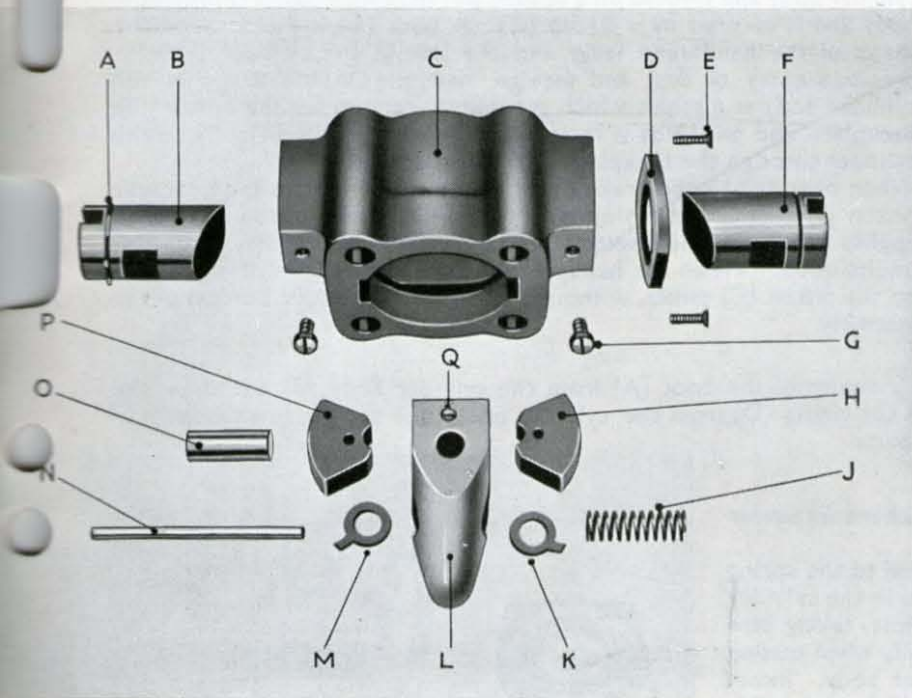

Fig. 47

Also housed in the bisector body, at right angles to the centre line, is an expander unit consisting of a fork (L) carrying two sectors (H, P) which bear against a pivot pin (O) and are positioned, each by a sector retainer (K, M) located on the pin. Across the extremity of the fork is a stop pin (Q) which acts as a guide for the sectors during assembly. The expander unit is retained in the bisector body by a pin (N) between which, and the recessed head of the fork, is a return spring (J). An inwards thrust on the domed head of the fork rolls the sectors between the inclined faces of the tappets, forcing them outwards.

DISMANTLING

Slacken off the set screw (G) and withdraw the tappets (B, F) from the body (C). Tap out the pin (N) and withdraw the expander unit. Press out the pivot pin (O) and remove the sectors (H, P), each with its retainer (K, M). Remove the return spring (J).

ASSEMBLING

Coat all internal parts **liberally** with Lockheed Expander Lubricant. Place a retainer (K, M) on the side of each sector (H, P) so that the cranked tongue engages the locating hole in the sector. Position the sectors in the end of the fork (L) so that the inner radii and the retainers are in alignment with the pivot pin hole, with the sectors butting against the stop pin and insert the pivot pin (O).

Place the return spring (J) in the recess in the head of the fork, insert the expander unit in the bisector body, compress the spring, fit the pin (N) and peen over the edges of the pin holes in the body. Insert the tappets (B, F) in correct alignment in the body, the one fitted with the circlip (A) from the opposite end to the abutment ring (D), and tighten down the locating screws (G)

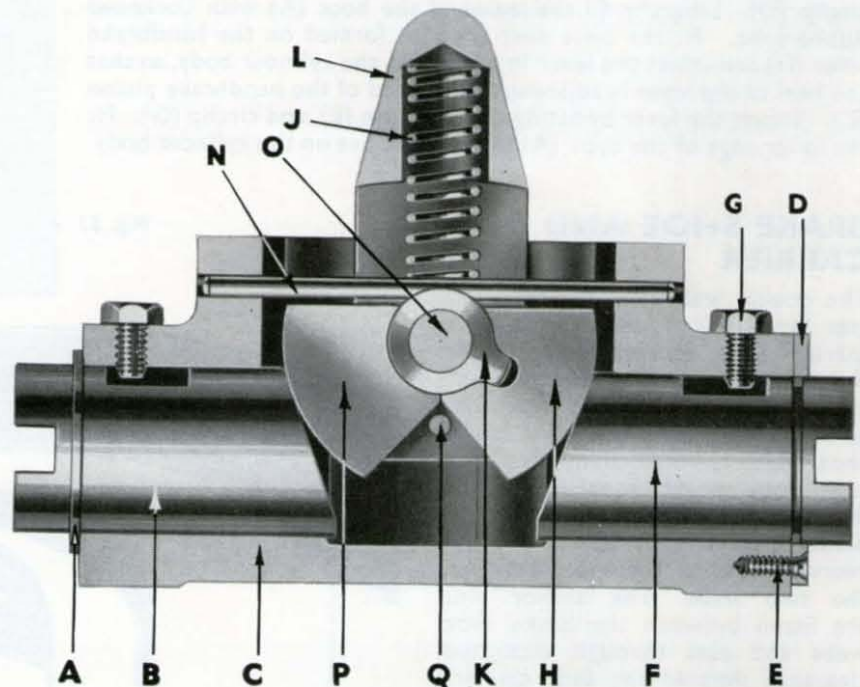

Fig. 48

TRANSVERSE WHEEL CYLINDER

The transverse wheel cylinder (see Figs. 49 and 50) is of the pusher type, incorporating a handbrake lever which is located between two pistons (J, C) within a body (B): the inner (or hydraulic) piston (J) is backed by a rubber cup (K), a spring retainer (L) and a return spring (M); and the outer (or handbrake) piston (C) is recessed to receive the domed head of the bisector fork (Fig. 47 Ref. L). The stroke of this latter piston is limited by a circlip (D) fitted in a groove in the mouth of the cylinder bore.

TRANSVERSE WHEEL CYLINDER (continued)

The adjoining faces of the two pistons are slotted to permit the entry of the heel of the handbrake lever (H), which is located in a slot in the cylinder body and pivoted on a headed pin (E) which passes through the body and is secured by a circlip (G). A boot (A) is fitted round the shank of the handbrake lever and the slot in the cylinder body to preclude entry of dust and foreign matter. On the flange of the cylinder body is a spigot which provides a location for the unit in the backplate, and on which is located the bisector secured rigidly to the cylinder through the backplate by four set screws.

When operated by the brake pedal, fluid pressure forces the hydraulic piston (J) outwards carrying with it the handbrake piston (C) which applies a thrust to the bisector fork while the handbrake lever remains undisturbed. When the handbrake is applied, the lever (H) operates on the piston (C) direct, without affecting the hydraulic portion of the assembly.

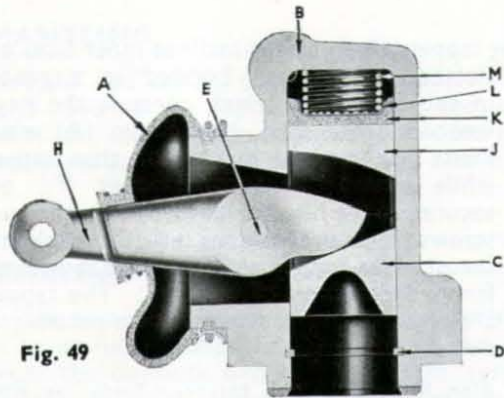

Fig. 49

DISMANTLING

Remove the circlip (G), withdraw the pivot pin (E), disengage the boot (A) from the cylinder body (B), withdraw the handbrake lever (H) and remove the boot. Remove the circlip (D) from the cylinder body, and apply a low pressure of air to the fluid connection to blow out the internal parts.

ASSEMBLING

During assembly smear the pivot pin (E) with Lockheed Expander Lubricant.

Ensure that the return spring (M) is securely attached to the spring retainer (L) and insert the assembly, spring foremost, in the cylinder (B). Follow up with the rubber cup (K), lip foremost, taking care not to turn back or damage the lip of the cup, especially when passing the circlip groove and the lever slot in the cylinder body. Insert the hydraulic piston (J) and the handbrake piston (C) in that order and align the slot in each with that in the cylinder body. Fit the circlip (D). Liberally fill the inside of the boot (A) with Lockheed Rubberlube. Fit the boot over the ribs formed on the handbrake lever (H) and insert the lever in the slot in the cylinder body, so that the heel of the lever is adjacent to the head of the handbrake piston (C). Secure the lever by fitting the pivot pin (E), and circlip (G). Fit the inner edge of the boot (A) into the groove on the cylinder body.

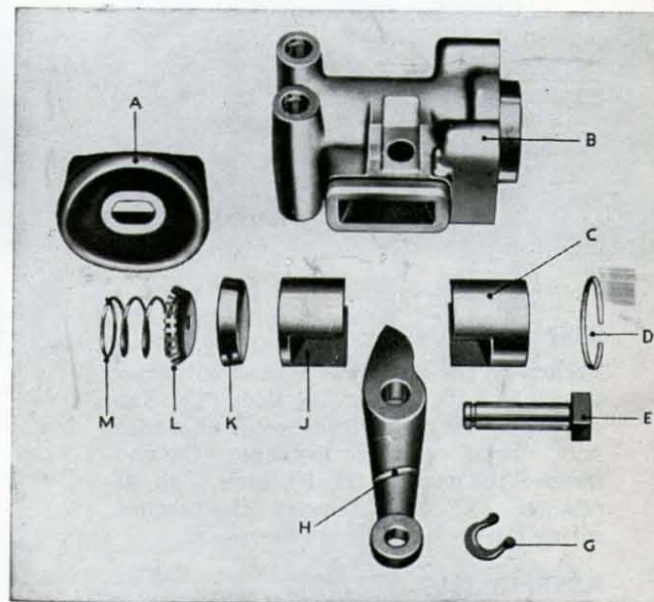

Fig. 50

BRAKE SHOE AND CARRIER

The double webbed brake shoe (A) (see Fig. 51) is mounted on a shoe carrier (D), contact being made through a brake shoe slider (B) and attachment being effected by means of two anchor pins (E). The brake shoe slider is retained by two stop pads, one being secured to the forward end of the shoe carrier platform and the other to the rearward end of the shoe, between the two webs. The anchor pins are fitted between the brake shoe webs and pass through elongated clearance slots in the shoe carrier; they are retained by circlips (F) fitted at each end.

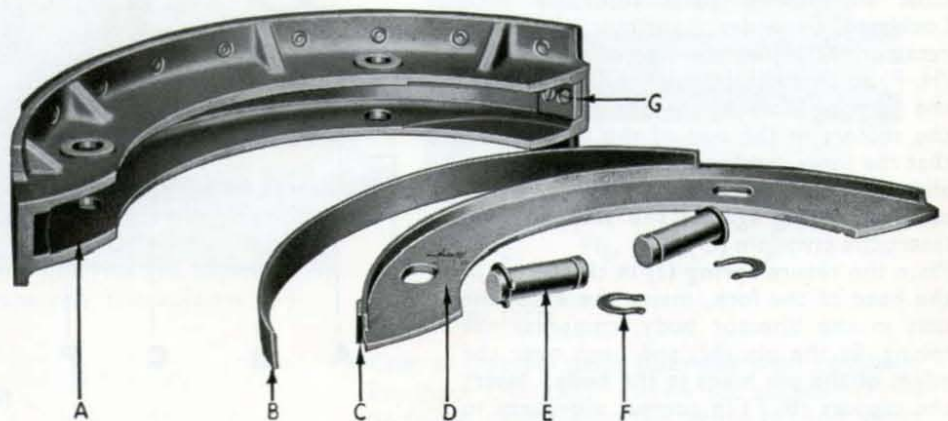

Fig. 51

DISMANTLING

Remove the circlips (F) from each of the anchor pins (E) and withdraw the pins. Withdraw the carrier (D) and the slider (B) from the brake shoe.

ASSEMBLING

Lightly smear the anchor pins, the anchor pin holes in the brake shoe and the slots in the carrier with Lockheed Expander Lubricant. Place the slider (B) in the bottom of the recess between the brake shoe webs, with one end against the stop pad. Insert the shoe carrier (D) so that the stop pads on its platform are adjacent to the opposite end of the slider. Insert the anchor pins (E) and secure each pin by means of the circlips (F).



One of the Automotive Products Group