

Starting System

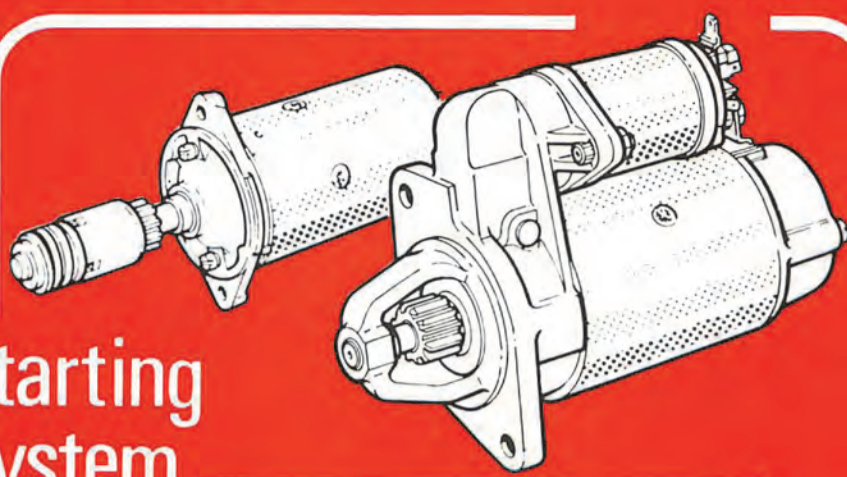

Lucas Electrical Limited Parts and Service Division
Great Hampton Street Birmingham B18 6AU

10p

RECOMMENDED TEST EQUIPMENT

D.C. Moving Coil Voltmeter Scale 0-20V
Hydrometer

Note:

1. Test figures quoted are typical only
2. During testing the engine should be cranked without starting:
Petrol — Disconnect coil to distributor LT lead
Diesel — Operate engine stop control

TEST:

1 HYDROMETER READING

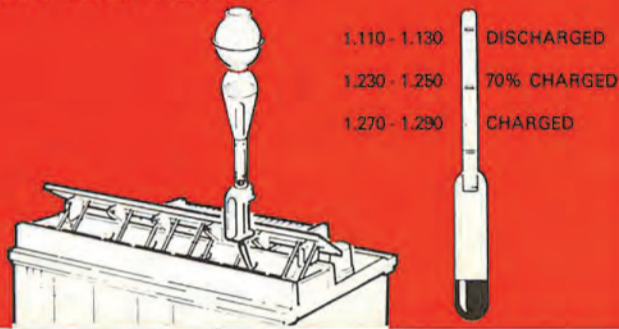

RESULT:

Below 1.230
Recharge and then test → TEST 2

1.230-1.290 → TEST 2

2 CONNECTIONS

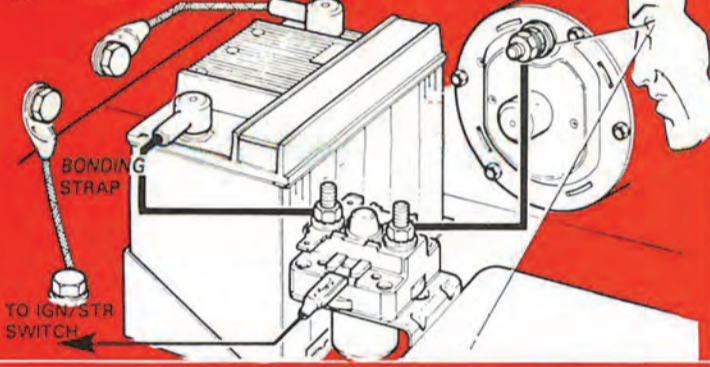

Clean and tight → TEST 3

Loose and/or dirty
Rectify → TEST 3

3 BATTERY VOLTAGE, ON LOAD

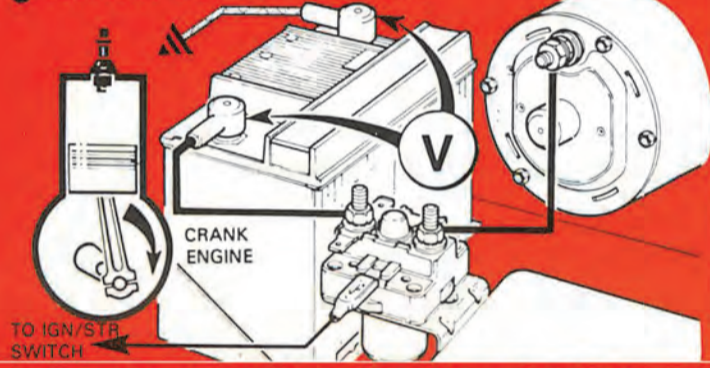

If starter does not motor check solenoid operation, supply cables and earth connections. Rectify.

Should be approx:
Inertia 10.5V
Pre-Engaged 10.0V → TEST 4

Below expected voltage, check battery state of charge and if low retest with good substitute battery → TEST 4

4 VOLTAGE AT SOLENOID OPERATING TERMINAL

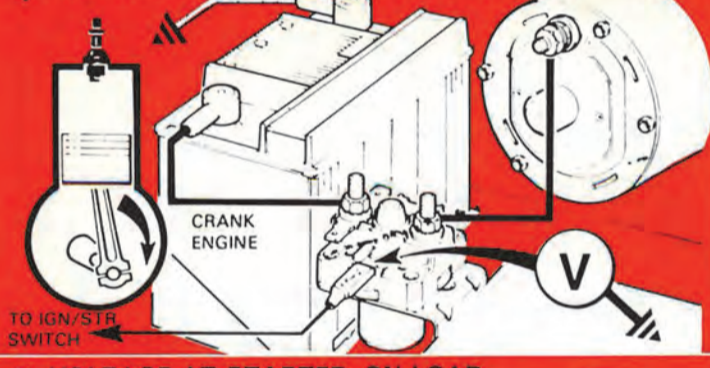

Should be:
Similar voltage to previous test → TEST 5

If voltage is lower than in previous test, check ignition/starter switch, all cables and connections etc. Rectify → TEST 5

See also note below

5 VOLTAGE AT STARTER, ON LOAD

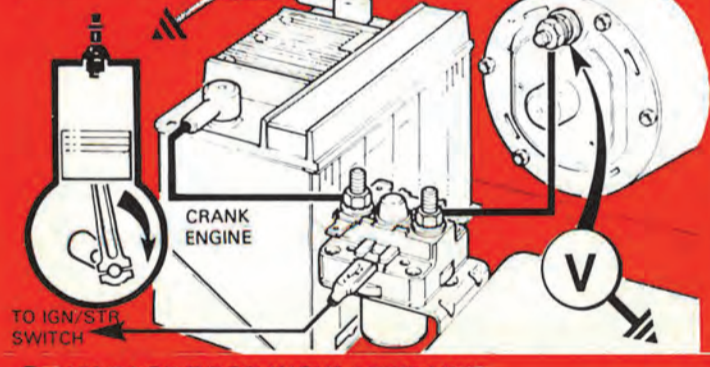

Should be:
Within 0.5V of voltage in test 3 → TEST 6

Circuit Satisfactory

Voltage more than 0.5V below reading in test 3 → TEST 6

6 VOLTAGE DROP, INSULATED LINE

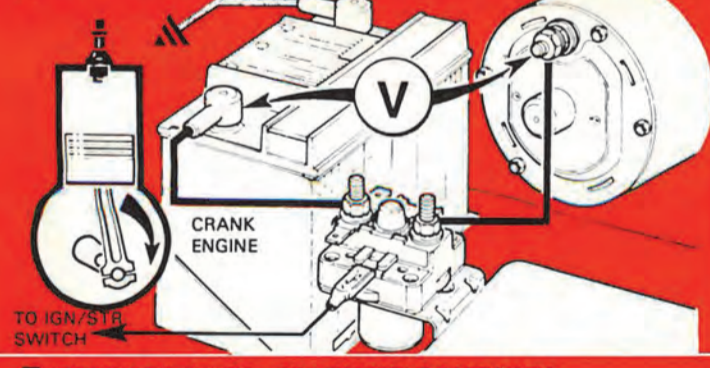

Should be:
Approx zero voltage → TEST 8

If above 0.5V → TEST 7

7 VOLTAGE DROP, SOLENOID CONTACTS

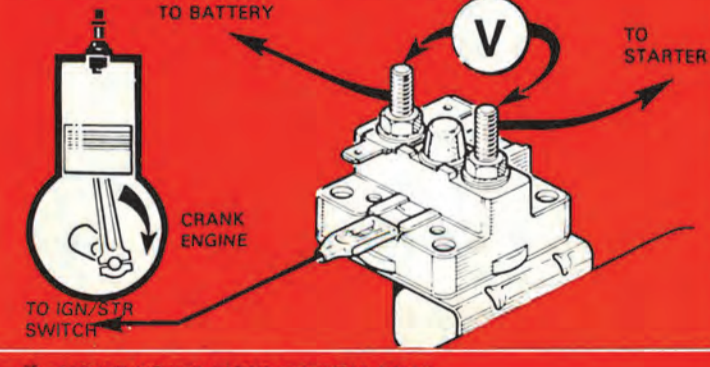

Should be:
Approx zero voltage.

If zero voltage is shown, solenoid is satisfactory and a fault exists elsewhere in the circuit. Check all insulated line cables and connections. Rectify. Recheck as test 6 → TEST 8

If above 0.25V Replace solenoid → TEST 8

8 VOLTAGE DROP, EARTH LINE

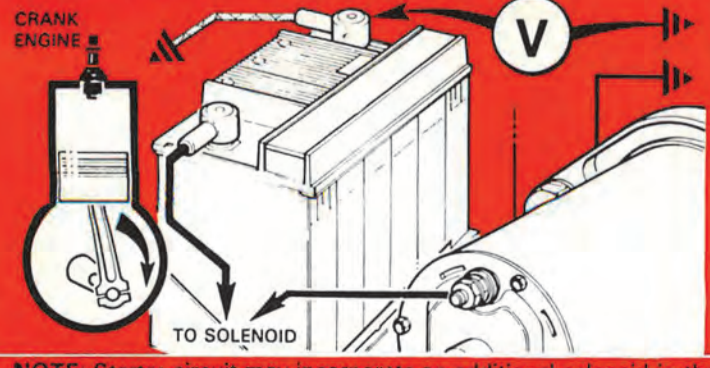

Should be:
Approx. zero voltage.

If above 0.25V check all earth connections including chassis/engine bonding strap.

NOTE: Starter circuit may incorporate an additional solenoid in the operating line (mainly commercial vehicle applications). Check operation of this solenoid.

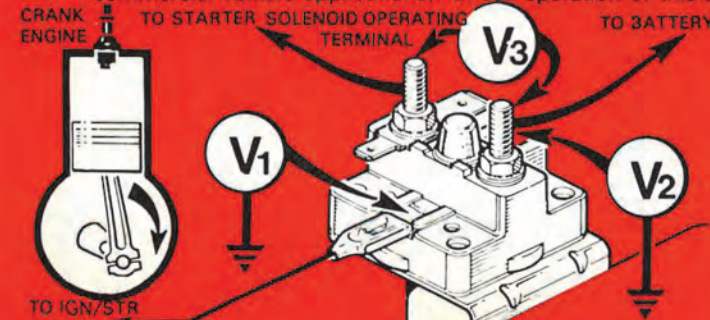

V1, V2 Must show same voltage as test 3. If lower check supply cables from battery and starter switch.

V3 should be zero. If more than zero is shown while cranking, replace solenoid.

If battery voltage is shown while attempting to crank the engine, check solenoid earth connections, and if satisfactory replace solenoid.